

# INSTALLATION INSTRUCTIONS AND OWNER'S MANUAL

## INSTALLER:

Leave this manual with the appliance.

## CONSUMER:

Retain this manual for future reference.

### ⚠ WARNING

#### FIRE OR EXPLOSION HAZARD

Failure to follow safety warnings exactly could result in serious injury, death or property damage.

- Do not store or use gasoline or other flammable vapors and liquids in the vicinity of this or any other appliance.
- **WHAT TO DO IF YOU SMELL GAS**
  - Do not try to light any appliance.
  - Do not touch any electrical switch; do not use any phone in your building.
  - Leave the building immediately.
  - Immediately call your gas supplier from a neighbor's phone. Follow the gas supplier's instructions.
  - If you cannot reach your gas supplier, call the fire department.
- Installation and service must be performed by a qualified installer, service agency or the gas supplier.

This appliance may be installed in an aftermarket permanently located, manufactured (mobile) home, where not prohibited by local codes.

This appliance is only for use with the type of gas indicated on the rating plate. This appliance is not convertible for use with other gases.

This is an unvented gas-fired heater. It uses air (oxygen) from the room in which it is installed. Provisions for adequate combustion and ventilation air must be provided. Refer to page 11.

## UNVENTED GAS LOG BURNER OR VENTED DECORATIVE BURNER MODELS:

GAS-FIRED  
UL US  
LISTED  
MH-46389

VFSUR(18,24,30)-3 | VFSUE(18,24,30)-2

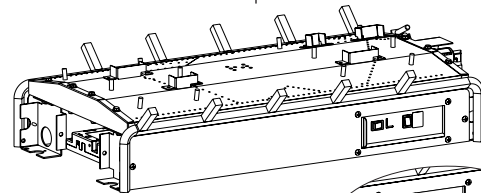

VISTA SLOPE GLAZE  
SEE-THRU OR  
PENINSULA BURNER

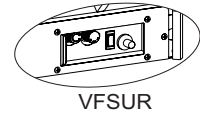

### ⚠ WARNING

If not installed, operated and maintained in accordance with the manufacturer's instructions, this product could expose you to substances in fuel or from fuel combustion which can cause death or serious illness.

#### WATER VAPOR: A BY-PRODUCT OF UNVENTED ROOM HEATERS

Water vapor is a by-product of gas combustion. An unvented room heater produces approximately one (1) ounce (30ml) of water for every 1,000 BTU's (.3KW's) of gas input per hour. Refer to page 11.

NATIONAL  
FIREPLACE  
INSTITUTE



CERTIFIED  
www.nficertified.org

We suggest that our gas hearth products be installed and serviced by professionals who are certified in the U.S. by the National Fireplace Institute® (NFI) as NFI Gas Specialists.

# TABLE OF CONTENTS

SECTION	PAGE
Carton Contents .....	3
Hardware Package.....	3
Important Soot Prevention Steps .....	4
Product Specifications.....	5
Important Safety Information .....	6
Safety Information For Users Of Propane Gas .....	7
Introduction.....	8
General Information.....	9
Requirements For Canada.....	10
Water Vapor: A By-Product Of Unvented Room Heaters .....	11
Provisions For Adequate Combustion & Ventilation Air.....	11
Clearances .....	12-13
Combustible Material.....	14
Fireplace Preparation .....	14
Placement Of VFSUE Control Module .....	15
Installing As A Vented Appliance .....	16
Mounting Into A Fireplace Or Firebox.....	16
Gas Supply.....	17
Placement Of Glowing Embers And Lava Rock.....	18
Operation Instructions/Flame Appearance .....	18
VFSUR(18,24,30) Lighting Instructions.....	19
VFSUR Wiring .....	20
VFSUR Troubleshooting.....	21
VFSUE(18,24,30) Lighting Instructions .....	22
VFSUE Wiring .....	23
VFSUE Remote Control Instructions.....	24-28
VFSUE Switch Operation .....	29
VFSUE Control System Specifications.....	30-32
VFSUE Troubleshooting Symptoms - Possible Causes & Correction.....	33
Burner Instructions .....	34
Pilot Flame Characteristics.....	35
Cleaning And Servicing .....	36
Appliance Service History .....	37
VFSUR(18,24,30) Parts List.....	38
VFSUR(18,24,30) Parts View.....	39
VFSUE(18,24,30) Parts List.....	40
VFSUE(18,24,30) Parts View.....	41
Master Parts Distributor List.....	42
How To Order Repair Parts .....	42
Warranty Terms .....	43

# CARTON CONTENTS

- BURNER ASSEMBLY
- LAVA ROCK PACKET
- SOOT WARNING SHEET

## INSTALLATION PACKAGE:

- Rockwool Package
- Damper Clamp
- Installation Instructions
- Serial Number Tag
- Warranty Card

## HARDWARE PACKAGE:

(See Figures Below)

- #10 X 1/2" Phillips Hex Head Screw (3)
- 1/4" X 1 1/4" Slotted Hex Head Anchor Screw (3)

# HARDWARE PACKAGE

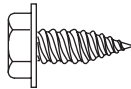

#10 X 1/2" PHILLIPS HEX HEAD SCREW (3)

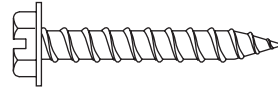

1/4" X 1 1/4" SLOTTED HEX HEAD ANCHOR SCREW (3)

Hardware shown to scale where possible.

# IMPORTANT SOOT PREVENTION STEPS

## ⚠ NOTICE IMPORTANT NOTICE ⚠

INSTALLER - SERVICE PERSON - HOMEOWNER

**SOOT MAY BE CREATED IF THE FOLLOWING DIRECTIONS ARE NOT FOLLOWED.**

### ⚠ WARNING

**Failure to keep the primary air openings of the burner clean may result in sooting and property damage.**

### ⚠ WARNING

**Before installing in a solid-fuel burning fireplace, the chimney flue and firebox must be cleaned of soot, creosote, ashes and loose paint by a qualified chimney cleaner.**

- Check that the correct air shutter is installed. See table on Page 5.
- Ensure burner, venturi, and air shutter are free of dirt, lint, animal hair (i.e. cat and dog) or anything that may block the needed air flow. See Cleaning and Servicing, Page 36.

### ⚠ WARNING

**Do not allow fans to blow directly into the fireplace. Avoid any drafts that alter burner flame patterns. Pay particular attention to ceiling fans and exhaust fans.**

- Do not place debris, logs or other articles on burner.
- Avoid the use of scented air fresheners while the fireplace is in operation. A residue can be produced which may produce soot.
- Avoid the use of decorative or scented candles while the fireplace is in operation. Soot may be produced from the by-products of a burning candle. Some candles also produce soot.
- Do not place rock wool (embers) over the large ports of the burner.
- Do not place lava rocks on burner or burner ports. Lava rock is only to be placed on the fireplace floor.
- Check level of ceramic media in burner, if burner has ceramic media. Burner should be full, up to the ported burner surface.
- Install logs according to the installation instructions. Do not alter log placement from the prescribed layout. Only use Empire logs made for this burner.
- Annual inspection and cleaning by your dealer or qualified service technician is recommended to prevent malfunction and/or sooting.
- Verify the venturi tube is not bent or distorted. The main burner orifice must be centered in the venturi tube for proper combustion and to prevent sooting.

# PRODUCT SPECIFICATIONS

MODEL	GAS	REGULATOR PRESSURE SETTING	GAS INLET PRESSURE MINIMUM	GAS INLET PRESSURE MAXIMUM
VFSUR	Natural	3.5" W.C.	5.0" W.C.	10.5" W.C.
	Propane	10.0" W.C.	11.0" W.C.	13.0" W.C.
VFSUE	Natural	3.5" W.C.	7.0" W.C.	10.5" W.C.
	Propane	10.0" W.C.	11.0" W.C.	13.0" W.C.

MODEL	GAS	VALVE TYPE	ORIFICE	BTU/HR. MINIMUM RATE	BTU/HR. MAXIMUM RATE
VFSU(R,E)18N	Natural	Millivolt	3.00mm	25,000	36,000
VFSU(R,E)18P	Propane	Millivolt	#50	25,000	36,000
VFSU(R,E)24N	Natural	Millivolt	3.10mm	26,500	38,000
VFSU(R,E)24P	Propane	Millivolt	#49	26,500	38,000
VFSU(R,E)30N	Natural	Millivolt	#30	28,000	40,000
VFSU(R,E)30P	Propane	Millivolt	1.90mm	28,000	40,000

**NOTICE:** Thermostats are for Vent-Free Applications only.

TABLE 1 - AIR SHUTTER OPENING (NATURAL GAS MODELS)		TABLE 2 - AIR SHUTTER OPENING (PROPANE GAS MODELS)	
Model	Air Shutter Opening & Color	Model	Air Shutter Opening
VFSUR18N	1/8" (Blue)	VFSU(R,E)18	Full Open
VFSUR24N	1/8" (Blue)	VFSU(R,E)24	Full Open
VFSUE18N	5/16" (Yellow)	VFSU(R,E)30	Full Open
VFSUE24N	5/16" (Yellow)		
VFSUE30N	5/16" (Yellow)		
VFSUR30N	5/16" (Yellow)		

ACCESSORIES			
Model	Description	Model	Description
EK-2	Embers Kit	FRBTC	Battery Operated Remote Control with Thermostat
ELH-1	Fireplace Hood for Vent-Free Logs - Black	FREC	Electric Remote Control - Manual
ELH-2	Fireplace Hood for Vent-Free Logs - Brass	FWS-1	Wall Switch
FRBC	Battery Operated Remote Control - Manual	TMV	Wall Thermostat, Millivolt - Reed Switch
FOR USE WITH VFSUE MODELS ONLY			
AD1106V	AC/DC Adapter		

**NOTICE:** For vented applications of the VFSUE models, an FRIP (non-thermostat) remote must be used.

# IMPORTANT SAFETY INFORMATION

**⚠ DANGER:** Indicates a hazardous situation which, if not avoided, will result in death or serious injury.

**⚠ WARNING:** Indicates a hazardous situation which, if not avoided, could result in death or serious injury.

**⚠ CAUTION:** Indicates a hazardous situation which, if not avoided, could result in minor or moderate injury.

**NOTICE:** Addresses practices not related to personal injury.

- An unvented room heater having an input rating of more than 6,000 Btu per hour shall not be installed in a bathroom
- An unvented room heater having an input rating of more than 10,000 Btu per hour shall not be installed in a bedroom or bathroom.
- Due to high temperatures, the appliance should be located out of traffic and away from furniture and draperies.
- Children and adults should be alerted to the hazard of high surface temperature and should stay away to avoid burns or clothing ignition.
- Young children should be carefully supervised when they are in the same room with the appliance.
- Do not place clothing or other flammable material on or near the appliance.
- Avoid the use of scented air fresheners (plug in type air fresheners, etc. ) while the log set is in operation. Air fresheners produce a residue in the air similar to candles and may produce a soot like substance.
- Avoid the use of scented or decorative candles while the log set is in operation. Candles produce a residue in the air that creates a soot like substance. Burning candles while the log set is operating magnifies the problem. It should be noted that candles, in general, produce soot. The amount of time burned and the quantity of candles burned will determine the amount of soot produced and deposited.
- Installation and repair should be done by a QUALIFIED SERVICE PERSON. This appliance should be inspected before use and at least annually by a professional service person. More frequent cleaning may be required due to excessive lint from carpeting, bedding materials, etc. It is imperative that control compartments, burners and circulating air passageways of the appliance be kept clean.
- DO NOT use this room heater if any part has been under water. Immediately call a qualified service technician to inspect the room heater and to replace any part of the control system and any gas control which has been under water.
- You must operate heater with fireplace screen in place.
- Do not place trash, logs or other articles on the log set during operation.
- During manufacturing, fabricating and shipping, various components of this appliance are treated with certain oils, films or bonding agents. These bonding agents are not harmful but may produce annoying smoke and smells as they are burned off during initial operation of the appliance. This is a normal temporary occurrence. A window should be opened during the initial bake out period.
- Correct installation of the ceramic fiber logs, proper location of the heater and annual cleaning are necessary to avoid potential problems with sooting. Sooting, resulting from improper installation or operation, can settle on surfaces outside the fireplace. See instructions for proper installation.
- **⚠ WARNING:** Do not allow fans to blow directly into the fireplace. Avoid any drafts that alter burner flame patterns.
- **⚠ WARNING:** Do not use a blower insert, heat exchanger insert or other accessory not approved for use with this heater.

- **⚠ WARNING!** This fireplace needs fresh air for ventilation to run properly. This fireplace has an ODS (oxygen depletion sensor) which will shut down the heater if adequate fresh air is not available. See troubleshooting section in the instructions.

- **⚠ WARNING:** DO NOT operate this appliance unless all components including logs, burners, and controls are in good working condition. Never operate this appliance if any log or twig is broken, or out of their intended position. Refer to the Log set placement instructions for correct log and twig positioning. Replacement components are available through your local dealer as indicated in the How to Order Repair Parts section of the appliance manual.

- Keep appliance area clear and free from combustible materials, gasoline and other flammable vapors and liquids.

- **⚠ WARNING:** Failure to keep the primary air opening(s) of the burner(s) clean may result in sooting and property damage.

## ⚠ WARNING

When used without adequate combustion and ventilation air, heater may give off CARBON MONOXIDE, an odorless, poisonous gas.

Do not install heater until all necessary provisions are made for combustion and ventilation air. Consult the written instructions provided with the heater for information concerning combustion and ventilation air. In the absence of instructions, refer to the National Fuel Gas Code, ANSI Z223.1/NFPA 54, Air for Combustion and Ventilation, or applicable local codes.

This heater is equipped with a PILOT LIGHT SAFETY SYSTEM designed to turn off the heater if not enough fresh air is available.

### DO NOT TAMPER WITH PILOT LIGHT SAFETY SYSTEM!

If heater shuts off, do not relight until you provide fresh air.

If heater keeps shutting off, have it serviced. Keep burner and control compartment clean.

### CARBON MONOXIDE POISONING MAY LEAD TO DEATH.

Early signs of carbon monoxide poisoning resemble the flu, with headache, dizziness and/or nausea. If you have these signs, heater may not be working properly. Get fresh air at once! Have heater serviced.

Some people — pregnant women, persons with heart or lung disease, anemia, those under the influence of alcohol, those at high altitudes — are more affected by carbon monoxide than others.

The pilot light safety system senses the depletion of oxygen at its location. If this heater is installed in a structure having a high vertical dimension, the possibility exists that the oxygen supply at the higher levels will be less than that at the heater. In this type of application, a fan to circulate the structure air will minimize this effect. The use of this fan will also improve the comfort level in the structure. When a fan is used to circulate air, it should be located so that the air flow is not directed at the burner.

# SAFETY INFORMATION FOR USERS OF PROPANE GAS

Propane is a flammable gas which can cause fires and explosions. In its natural state, propane is odorless and colorless. You may not know all the following safety precautions which can protect both you and your family from an accident. Read them carefully now, then review them point by point with the members of your household. Someday when there may not be a minute to lose, everyone's safety will depend on knowing exactly what to do. If, after reading the following information, you feel you still need more information, please contact your gas supplier.

## PROPANE GAS WARNING ODOR

**If a gas leak happens, you should be able to smell the gas because of the odorant put in the Propane Gas. That's your signal to go into immediate action!**

- Do not operate electric switches, light matches, use your phone. Do not do anything that could ignite the gas.
- Get everyone out of the building, vehicle, trailer, or area. Do that IMMEDIATELY.
- Close all gas tank or cylinder supply valves.
- Propane Gas is heavier than air and may settle in low areas such as basements. When you have reason to suspect a gas leak, keep out of basements and other low areas. Stay out until firefighters declare them to be safe.
- Use your neighbor's phone and call a trained Propane Gas service person and the fire department. Even though you may not continue to smell gas, do not turn on the gas again. Do not re-enter the building, vehicle, trailer, or area.
- **Finally**, let the service man and firefighters check for escaped gas. Have them air out the area before you return. Properly trained Propane Gas service people should repair the leak, then check and relight the gas appliance for you.

## NO ODOR DETECTED - ODOR FADE

**Some people cannot smell well. Some people cannot smell the odor of the chemical put into the gas. You must find out if you can smell the odorant in propane.** Smoking can decrease your ability to smell. Being around an odor for a time can affect your sensitivity or ability to detect that odor. Sometimes other odors in the area mask the gas odor. People may not smell the gas odor or their minds are on something else. Thinking about smelling a gas odor can make it easier to smell.

**The odorant in Propane Gas is colorless, and it can fade under some circumstances.** For example, if there is an underground leak, the movement of the gas through soil can filter the odorant. Odorants in Propane Gas also are subject to oxidation. This fading can occur if there is rust inside the storage tank or in iron gas pipes.

The odorant in escaped gas can adsorb or absorb onto or into walls, masonry and other materials and fabrics in a room. That will take some of the odorant out of the gas, reducing its odor intensity.

Propane Gas may stratify in a closed area, and the odor intensity could vary at different levels. Since it is heavier than air, there may be more odor at lower levels. Always be sensitive to the slightest gas odor. If you detect any odor, treat it as a serious leak. Immediately go into action as instructed earlier.

## SOME POINTS TO REMEMBER

- Learn to recognize the odor of Propane Gas. Your local Propane Gas Dealer can give you a "Scratch and Sniff" pamphlet. Use it to find out what the propane odor smells like. If you suspect that your Propane Gas has a weak or abnormal odor, call your Propane Gas Dealer.
- If you are not qualified, do not light pilot lights, perform service, or make adjustments to appliances on the Propane Gas system. If you are qualified, consciously think about the odor of Propane Gas prior to and while lighting pilot lights or performing service or making adjustments.
- Sometimes a basement or a closed-up house has a musty smell that can cover up the Propane Gas odor. Do not try to light pilot lights, perform service, or make adjustments in an area where the conditions are such that you may not detect the odor if there has been a leak of Propane Gas.
- Odor fade, due to oxidation by rust or adsorption on walls of new cylinders and tanks, is possible. Therefore, people should be particularly alert and careful when new tanks or cylinders are placed in service. Odor fade can occur in new tanks, or reinstalled old tanks, if they are filled and allowed to set too long before refilling. Cylinders and tanks which have been out of service for a time may develop internal rust which will cause odor fade. If such conditions are suspected to exist, a periodic sniff test of the gas is advisable. **If you have any question about the gas odor, call your Propane Gas dealer. A periodic sniff test of the Propane Gas is a good safety measure under any condition.**
- If, at any time, you do not smell the Propane Gas odorant and you think you should, assume you have a leak. Then take the same immediate action recommended above for the occasion when you do detect the odorized Propane Gas.
- If you experience a complete "gas out," (the container is under no vapor pressure), turn the tank valve off immediately. If the container valve is left on, the container may draw in some air through openings such as pilot light orifices. If this occurs, some new internal rusting could occur. If the valve is left open, then treat the container as a new tank. Always be sure your container is under vapor pressure by turning it off at the container before it goes completely empty or having it refilled before it is completely empty.

# INTRODUCTION

**IMPORTANT:** Read all instructions carefully before starting installation. Failure to follow these installation instructions may result in a possible fire hazard and will void the warranty. Save this manual for future reference.

Please read this manual before installing and using the appliance.

## INSTRUCTIONS TO INSTALLER

1. Installer must leave instruction manual with owner after installation.
2. Installer must have owner fill out and mail warranty card supplied with unvented room heater/vented decorative appliance.
3. Installer should show owner how to start and operate unvented room heater/vented decorative appliance.

Always consult your local Building Department regarding regulations, codes or ordinances which apply to the installation of an unvented room heater/vented decorative appliance.

This appliance may be installed in an aftermarket\* manufactured (mobile) home, where not prohibited by state or local codes.

\*Aftermarket: Completion of sale, not for purpose of resale, from the manufacturer.

## WELL HEAD GAS INSTALLATIONS

Some natural gas utilities use "well head" gas. This may affect the Btu output of the unit and promote sooting. Units shall not be converted to use well head gas.

This appliance is only for use with the type of gas indicated on the rating plate. This appliance is not convertible for use with other gases.

## NEW INSTALLATION

Solid-fuels shall not be burned in a fireplace where a vented decorative appliance is installed.

A vented decorative appliance must be installed only in a solid-fuel burning fireplace with a working flue and constructed of non-combustible material.

**Any alteration of the original design, installed other than as shown in these instructions or use with a type of gas not shown on the rating plate is the responsibility of the person and company making the change.**

## IMPORTANT

All correspondence should refer to complete Model Number, Serial Number and type of gas.

**Attention:** During initial use of log you will detect an odor as the log is cured.

**NOTICE:** During initial firing of this unit, its paint will bake out, and smoke will occur. To prevent triggering of smoke alarms, ventilate the room in which the unit is installed.

### WARNING

This appliance is for installation only in a solid-fuel burning masonry or *UL 127* factory-built fireplace or in a listed ventless firebox enclosure. It has been design certified for these installations. Exception: **DO NOT** install this appliance in a factory-built fireplace that includes instructions stating it has not been tested or should not be used with unvented gas logs.

### WARNING

Any modification to this unvented gas heater or its controls can be dangerous. Improper installation or use of the heater can cause serious injury or death from fire, burns, explosion or carbon monoxide poisoning.



# GENERAL INFORMATION

This is an unvented gas-fired heater. It uses air (oxygen) from the room in which it is installed. Provisions for adequate combustion and ventilation air must be provided.

Keep room area clear and free from combustible materials, gasoline and other flammable vapors and liquids.

Unvented gas heaters are a supplemental zone heater. They are not intended to be a primary heating appliance. Water vapor produced by an unvented heater can create moisture problems in a home when operated for extended periods of time.

During manufacturing, fabricating and shipping, various components of this appliance are treated with certain oils, films or bonding agents. These chemicals are not harmful but may produce annoying smoke and smells as they are burned off during the initial operation of the appliance; possibly causing headaches or eye or lung irritation. This is a normal and temporary occurrence.

The initial break-in operation should last 2-3 hours with the burner at the highest setting. Provide maximum ventilation by opening windows or doors to allow odors to dissipate. Any odors remaining after this initial break-in period will be slight and will disappear with continued use.

This appliance must not be used with glass doors in the closed position. This can lead to pilot outages and severe sooting outside the fireplace.

Do not use this room heater if any part has been under water. Immediately call a qualified service technician to inspect the room heater and replace any part of the control system and any gas control which has been under water.

## WARNING

**This appliance is equipped for (Natural or Propane) Gas. Field conversion is not permitted.**

### BEFORE YOU GET STARTED

Carefully inspect the contents for shipping damage. If any parts are missing or damaged, immediately inform the dealer from whom you purchased the appliance. Do not attempt to install any part of the appliance unless you have all parts in good condition.

Millivolt controlled heater (VFSUR) designed to be operated with optional devices for ON/OFF functions.

- Wall switch or thermostat with wire.
- Hand held remote control with ON/OFF switch or thermostat.

**Handle the gas log burner assembly by the grate and legs only. Do not pick the unit up by the burner.**

**Gloves are recommended when handling logs to prevent skin irritation. Logs are fragile - Handle with care.**

### Qualified Installing Agency

Installation and replacement of gas piping, gas utilization equipment or accessories and repair and servicing of equipment shall be performed only by a qualified agency. The term "qualified agency" means any individual, firm, corporation, or company that either in person or through a representative is engaged in and is responsible for (a) the installation, testing, or replacement of gas piping or (b) the connection, installation, testing, repair, or servicing of equipment; that is experienced in such work; that is familiar with all precautions required, and that has complied with all the requirements of the authority having jurisdiction.

**Commonwealth of Massachusetts:** The installation must be made by a licensed plumber or gas fitter in the Commonwealth of Massachusetts.

Sellers of Unvented Propane or Natural Gas-Fired supplemental room heaters shall provide to each purchaser a copy of 527 CMR-30 upon sale of the unit.

In the Commonwealth of Massachusetts, Unvented Propane and Natural Gas-Fired space heaters shall be prohibited in bedrooms and bathrooms.

The installation must conform with local codes or, in the absence of local codes, with the National Fuel Gas Code, ANSI Z223.1\* or International Fuel Gas Code.

*\*Available from the American National Standards Institute, Inc. 11 West 42nd St., New York, N.Y. 10018.*

# REQUIREMENTS FOR CANADA

This unit **cannot** be installed in a UNVENTED application, this unit **can only** be installed as a VENTED application with these requirements.

## IMPORTANT SAFETY INFORMATION

This unit complies with ANSI Z21.60 and CGA 2.26 Decorative Gas Appliances For Installation In Solid Fuel Burning Fireplaces. Do not burn wood or solid fuels in a fireplace where a decorative gas log set is installed. This appliance is for installation only in a solid fuel burning fireplace, masonry fireplace or manufactured fireplace.

### WARNING

**Any modification to this gas log set or to controls can be dangerous. Improper installation or use of the gas log set can cause serious injury or death from fire, burns, explosion or carbon monoxide poisoning.**

1. Please follow all local codes regarding installation, combustion and ventilation air or in the absence of local codes follow the National Fuel Gas Code ANSI Z223.1(U.S. installation), or CAN/CGA-B149, Installation Code (Canada installation).
2. Proper installation, burner pan location and log placement is important to achieve optimum look and performance of your gas log set. The logs have been designed for easy location and placement on the grate and must be followed for proper operation.
3. Do not operate this log set with glass doors in the closed position. A fireplace screen must be in place when the log set is burning. Adequate combustion air must be provided for proper venting. All flames should go up and out the top of the firebox into the flue vent. If any flames float or curl forward into the room do not operate appliance. Check for an open flue and adequate combustion air into the room. A damper clamp must be installed on the firebox damper to maintain an open flue vent condition. Refer to page 16 INSTALLING DAMPER CLAMP
4. Young children must be carefully supervised when they are in the same room as the gas log while in operation. Do not place stockings, clothing or any flammable material above or near the fireplace.
5. Do not substitute or use materials other than those supplied for use with the log set.
6. Also refer to IMPORTANT SAFETY INFORMATION on page 6 of this manual

### WARNING

**Do not operate this gas log set with glass doors closed**

- Clothing or other flammable material should not be placed on or near the appliance.
- Do not place trash or other articles on the log set during operation.
- During manufacturing, fabricating and shipping, various components of this appliance are treated with certain oils, films or bonding agents. These bonding agents are not harmful but may produce annoying smoke and smells as they are burned off during initial operation of the appliance. This is a normal temporary occurrence. A window should be opened during the initial bake out period.
- Keep burner and control compartment clean.

### WARNING

**Before installing in a solid fuel burning fireplace, the chimney flue and firebox must be cleaned of soot, creosote, ashes and loose paint by a qualified chimney cleaner.**

- Installation and repair should be done by a qualified service person. The appliance should be inspected before use and at least annually by a qualified service person. More frequent cleaning may be required due to excessive lint from carpeting, bedding materials, etc. It is imperative that control compartments, burners and circulating air passageways of the appliance be kept clean.
- **Do not** put anything around the fireplace that will obstruct the flow of ventilation air.
- **Do** keep the appliance area clear and free from combustible material, gasoline and other flammable vapors and liquids.
- A yearly examination and cleaning of the venting system of the solid-fuel burning fireplace must be performed by a qualified agency.
- **Do** make a periodic visual check of pilot and burners. Clean and replace damaged parts.
- **Do not** use this appliance if any part has been under water. Immediately call a qualified service technician to inspect the appliance and to replace any part of the control system and any gas control which has been under water.
- Never burn solid fuels in fireplace where a gas log set is installed.
- This unit complies with ANSI Z21.60 Decorative Vented Appliances for Solid Fuel Burning Fireplaces. State or local codes may only allow operation of this appliance in a vented configuration. Check your state or local codes.

# WATER VAPOR: A BY-PRODUCT OF UNVENTED ROOM HEATERS

Water vapor is a by-product of gas combustion. An unvented room heater produces approximately one ounce (30ml) of water for every 1,000 BTU's (.3KW's) of gas input per hour.

Unvented room heaters must be used as supplemental heat (a room) rather than a primary heat source (an entire house). In most supplemental heat applications, the water vapor does not create a problem. In most applications, the water vapor enhances the low humidity atmosphere experienced during cold weather.

The following steps will help insure that water vapor does not become a problem.

1. Be sure the heater is sized properly for the application, including ample combustion air and circulation air.
2. If high humidity is experienced, a dehumidifier may be used to help lower the water vapor content of the air.
3. Do not use an unvented room heater as the primary heat source (an entire house).

## PROVISIONS FOR ADEQUATE COMBUSTION & VENTILATION AIR

This heater shall not be installed in a confined space unless provisions are provided for adequate combustion and ventilation air.

A confined space is an area with volume less than 50 cubic feet per 1,000 Btuh of the combined input rates of all appliances drawing combustion air from that space. Small areas such as equipment rooms are confined spaces. Furnaces installed in a confined space which supply heated air to areas outside the space must draw return air from outside the space through tightly sealed return air ducts. A confined space must have 2 openings into the space for combustion air. One opening must be within 12 inches of the ceiling and the other must be within 12 inches of the floor. The required sizing of these openings is determined by whether inside or outside air is used to support combustion, the method by which the air is brought to the space (vertical or horizontal duct) and by the total input rate of all appliances in the space.

### Unusually Tight Construction

The air that leaks around doors and windows may provide enough fresh air for combustion and ventilation. However, in buildings of unusually tight construction, you must provide additional fresh air.

**Unusually tight construction is defined as construction where:**

- a. Walls and ceilings exposed to the outside atmosphere have a continuous water vapor retarder with a rating of one perm or less with openings gasketed or sealed, and
- b. Weather-stripping has been added on openable windows and doors, and
- c. Caulking or sealants are applied to areas such as joints around window and door frames, between sole plates and floors, between wall-ceiling joints, between wall panels, at penetrations for plumbing, electrical, and gas lines, and at other openings.

If your home meets all of the three criteria above, you must provide additional fresh air.

Example of Large Room with 1/2 Wall divider.

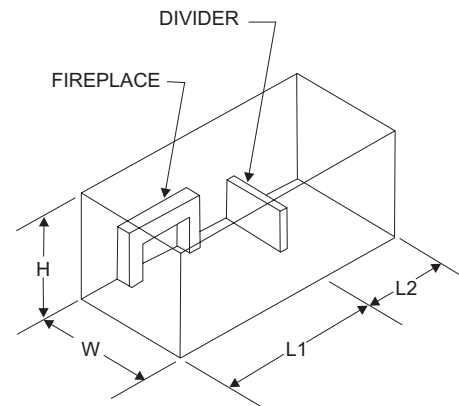

Figure 1

The following formula can be used to determine the maximum heater rating per the definition of unconfined space:

$$\text{Btu/Hr} = \frac{(L_1 + L_2)\text{FT} \times (W)\text{FT} \times (H)\text{FT}}{50} \times 1000$$

If the area in which the heater may be operated is smaller than that defined as an unconfined space, provide adequate combustion and ventilation air by one of the methods described in the National Fuel Gas Code, ANSI Z223.1, Section 5.3.

Adhere to all codes, or in their absence, the latest edition of THE NATIONAL FUEL GAS CODE ANSI Z223.1 or NFPA54 which can be obtained from:

American National Standards Institute National Fire Protection Association, Inc.

11 West 42nd St.  
New York, NY 10018

Batterymarch Park  
Quincy, MA 02269

### WARNING

If the area in which the heater may be operated is smaller than that defined as an unconfined space or if the building is of unusually tight construction, provide adequate combustion and ventilation air by one of the methods described in the National Fuel Gas Code, ANSI Z223.1, Section 5.3., International Fuel Gas Code, or applicable local codes.

# CLEARANCES

## Minimum Dimensions For Solid Fuel Burning Fireplaces UL127 Factory Built Fireplaces (Figure 2)

MODEL	A	B	C
VFSU(R,E)18	22	17	17
VFSU(R,E)24	28	17	18
VFSU(R,E)30	32	17	18

The dimensions shown and defined in the fireplace manufacturer's instructions are minimum clearances to maintain in installing this heater. Left and right clearances are determined when facing the front of the heater.

### GLASS DOORS

Make sure that glass doors are open during all operations of the logset. The opening of the glass door frame should be the dimension used for the minimum front opening of the firebox.

Follow these instructions to ensure safe installation.

Failure to follow instructions exactly can create a fire hazard.

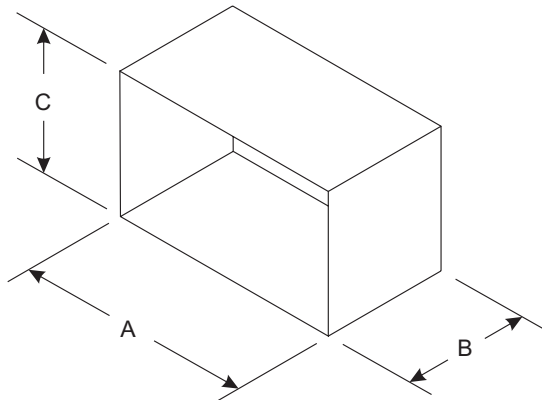

Figure 2

### Sidewall And Ceiling Clearances

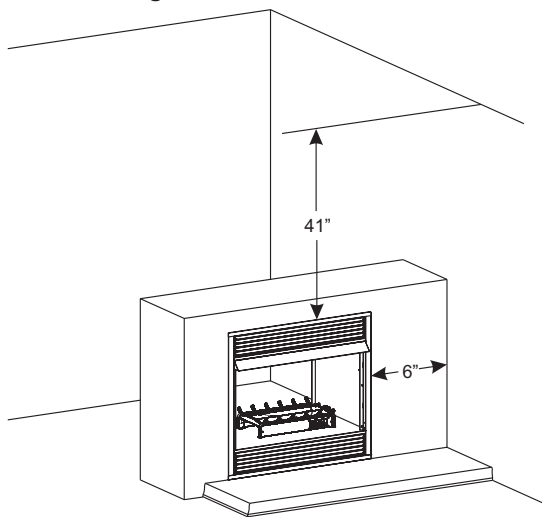

Figure 3

Clearances to combustibles must be as stated in the manufacturer's Installation Instructions and/or Owner's Manual of the firebox this unit will be used in. If no clearances to combustibles are listed, the clearances must be as follows: The sides of the fireplace opening must be 6" from any combustible wall. The ceiling must be at least 41" from the fireplace opening. See Figure 3.

### Mantel Clearances Without Hood

You must have non-combustible materials above the fireplace opening. Non-combustible material must extend at least 12" above fireplace opening. With sheet metal, you must have non-combustible material behind it.

Heat resistant materials such as slate and marble must be at least 1/2" thick. Sheet metal should not be installed onto combustible material.

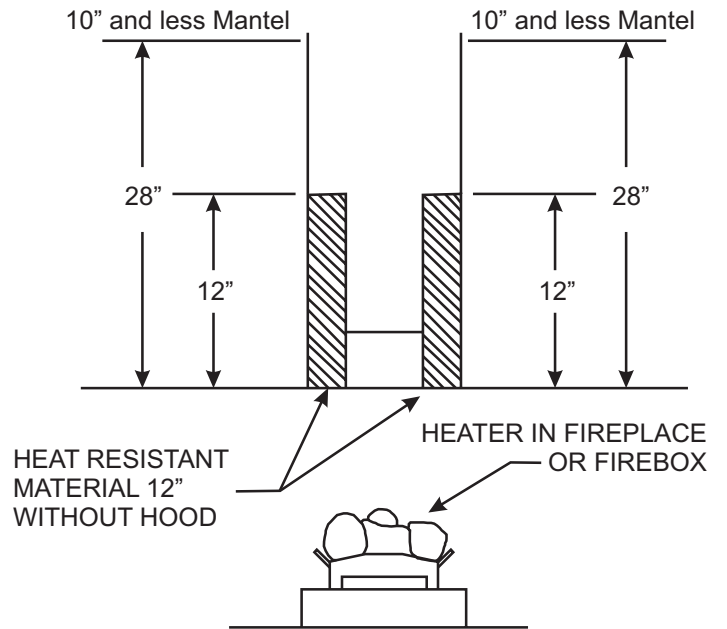

Figure 4

If your installation does not meet the above clearances, you must proceed to one of the following steps:

- Use a hood.
- Operate the heater with flue damper open. See page 16 for **Installing as a Vented Appliance.**
- Raise the mantel to the proper height.
- Remove the mantel.

Non-Combustible Material Distance	Requirements for Safe Installation
12" or more	Non-combustible material.
Less than 12"	Non-combustible material must be extended to at least 8" with the installation of the optional fireplace hood. If you cannot extend non-combustible material at least 8", you must operate heater with flue damper open.

# CLEARANCES (CONT'D)

## Mantel Clearances with Hood

You must have non-combustible materials above the fireplace opening. Non-combustible material must extend at least 8" above fireplace opening. With sheet metal, you must have non-combustible material behind it.

Heat resistant materials such as slate and marble must be **at least 1/2" thick. Sheet metal should not be installed onto combustible material.**

**Example:** A mantel may project from the wall a maximum of 2" at a minimum of 8" above the opening, and a maximum of 6" at a minimum of 15" above the opening.

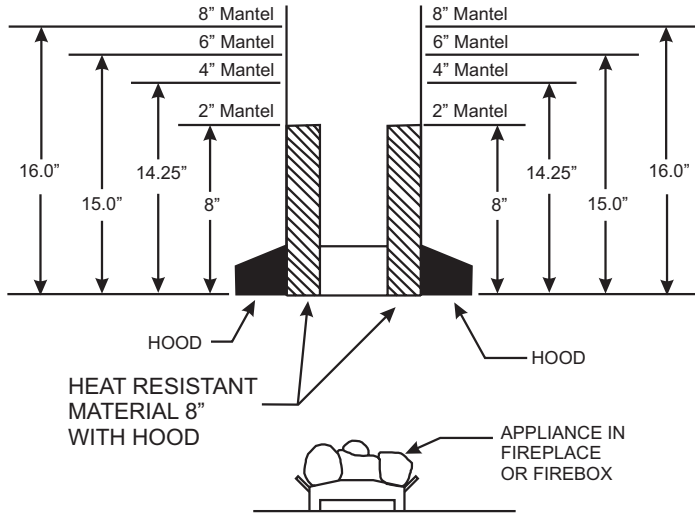

Figure 5

If your installation does not meet the above minimum clearances, you must proceed to one of the following steps:

- Operate the heater with the flue damper open. See page 16 for **Installing as a Vented Appliance.**
- Raise the mantel to the proper height.
- Remove the mantel.

## Floor Clearance

If installing heater at floor level, the minimum distance to combustibles is "0" inches.

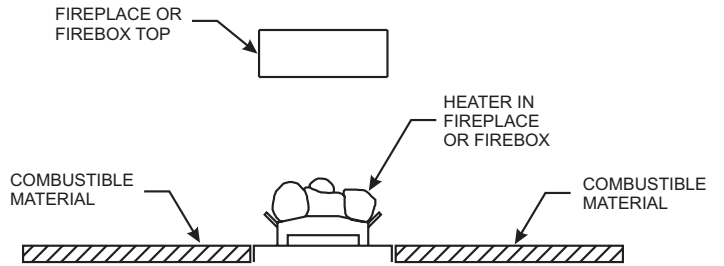

Figure 6

**NOTE:** If floor is sunken below the opening, the unit needs to be raised above the hearth level or the opening of the glass door surround.

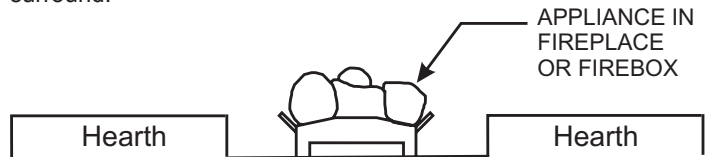

Figure 6a

# COMBUSTIBLE MATERIAL

Do not attach combustible material to the mantel of your fireplace. This is a fire hazard.

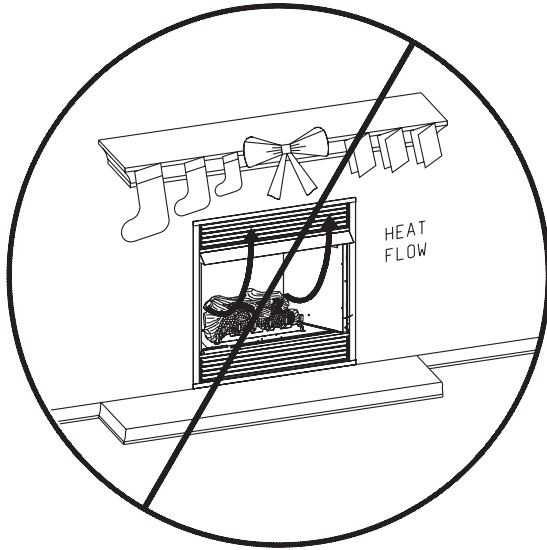

Figure 7

No greeting card, stockings or ornamentation of any type should be placed on or attached to the fireplace. This is a heating appliance. The flow of heat can ignite combustibles.

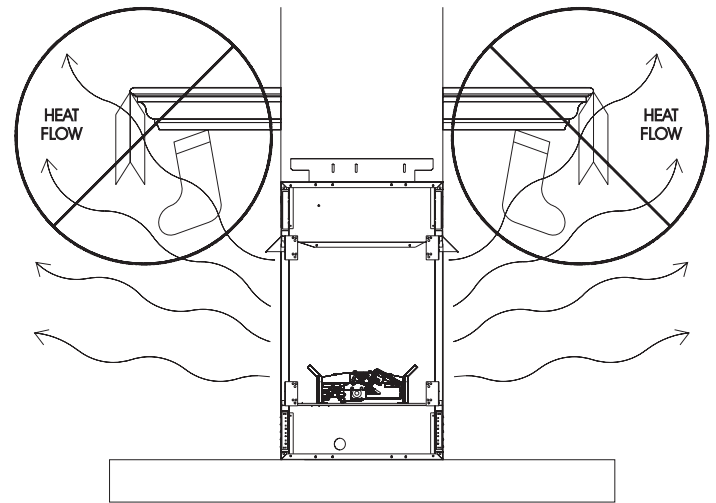

Figure 8

# FIREPLACE PREPARATION

## FOR INSTALLATION INTO A SEE - THRU OR PENINSULA FIREPLACE

- Turn off gas supply to fireplace or firebox.
- Have the fireplace floor and chimney professionally cleaned to remove ashes, soot, creosote or other obstructions. Have this cleaning performed annually after installation.

- Seal any fresh air vents or ash clean-out doors located on floor or wall of fireplace. If not, drafting may cause pilot outage or sooting. Use a heat-resistant sealant. Do not seal chimney flue damper.
- Install and operate the appliance as directed in this manual.

### FOR FACTORY BUILT FIREPLACES

#### FREE OPENING AREA OF CHIMNEY DAMPER FOR VENTING COMBUSTION PRODUCTS FROM DECORATIVE APPLIANCES FOR INSTALLATION IN SOLID FUEL BURNING FIREPLACES

CHIMNEY HEIGHT* (ft)	APPLIANCE INPUT RATE (BTU/hr)		
	20	30	40
	Minimum Opening** (sq. in.)		
10	11.3	16.6	22.1
15	8.6	12.6	17.3
20	7.5	10.8	14.5
25	6.6	9.6	12.6
30	6.2	9.1	11.3
35	5.7	8.0	10.8
40	5.3	7.5	10.2

\* Height is from hearth to top of chimney and the minimum height is 10 feet.

\*\* Chart shows minimum opening (sq. in.) for given height and input rate.

### FOR MASONRY BUILT FIREPLACES

#### FREE OPENING AREA OF CHIMNEY DAMPER FOR VENTING COMBUSTION PRODUCTS FROM DECORATIVE APPLIANCES FOR INSTALLATION IN SOLID FUEL BURNING FIREPLACES

CHIMNEY HEIGHT* (ft)	APPLIANCE INPUT RATE (BTU/hr)		
	20	30	40
	Minimum Opening** (sq. in.)		
6	17.6	25.7	33.8
8	16.5	23.7	31.2
10	15.1	21.7	28.7
15	14.1	19.9	26.1
20	12.9	18.5	23.7
30	12.2	16.9	21.6

\* Height is from hearth to top of chimney and the minimum height is 6 feet.

\*\* Chart shows minimum opening (sq. in.) for given height and input rate.

# PLACEMENT OF VFSUE CONTROL MODULE & BATTERY PACK

The control module is attached beneath the burner at the manufacturer. Use caution to keep all the wire connections in place when removing the burner and battery pack from the carton.

During appliance installation, place the battery pack on the pilot side of the burner, but **not under the burner**.

Insert 4 AA batteries into the battery pack. Follow the directions on page 28 to learn the remote to the control module.

**NOTICE:** After the appliance has been installed, lava rock can be used to hide the battery pack.

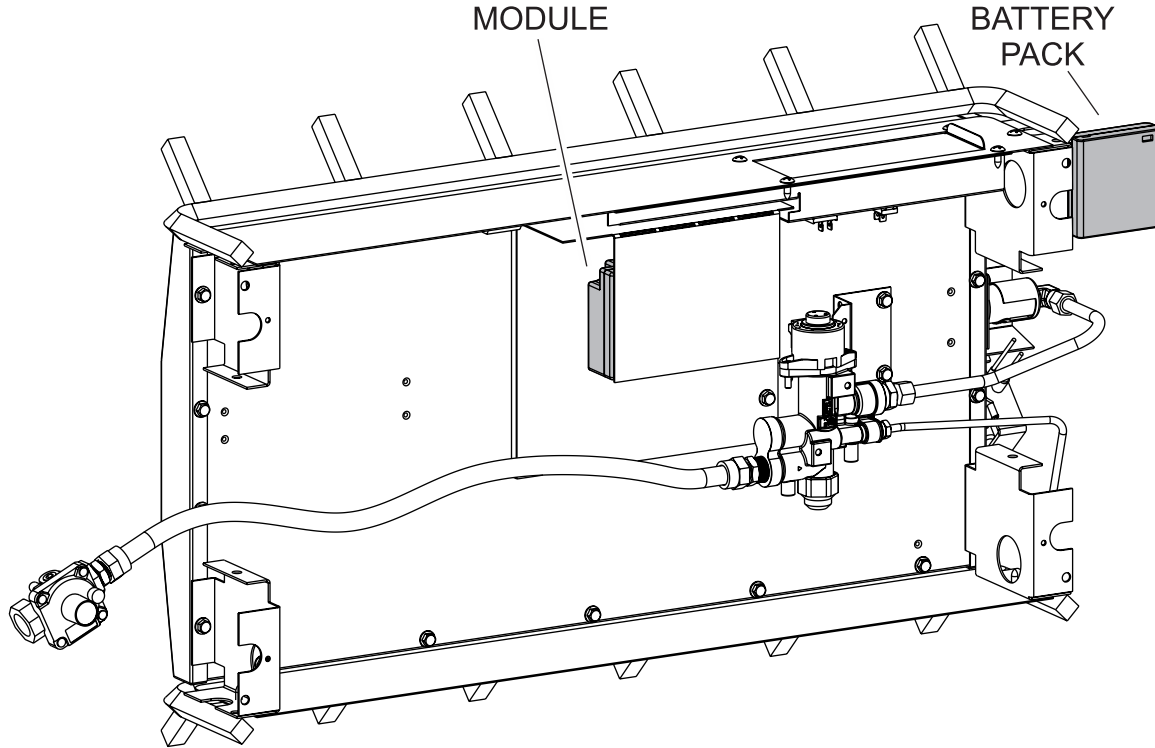

# INSTALLING AS A VENTED APPLIANCE

**NOTICE:** (Damper Clamp Installation)

When installing your log set as a vented installation the damper clamp must be used.

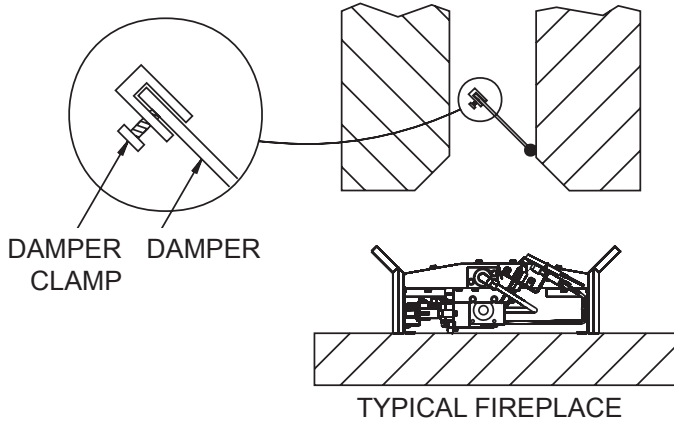

Figure 11

When installing your log set as a vent-free installation the damper clamp can be used to eliminate the potential for odors when burning the logs for the first time.

**Installing Damper Clamp**

Remove all ashes or other debris from the fireplace. If the fireplace is equipped with an ash dump be sure to seal the door with furnace cement or high temperature silicone. Be sure to check the damper for proper operation and verify that the flue passageway is open.

Place the clamp over the lip of the damper and tighten the hold down bolt until the clamp is securely attached to the damper. This will prevent the damper from accidentally closing.

Manual and millivolt controlled gas logs may be installed as a vented decorative log set in compliance with ANSI Z21.60 and National Fuel Gas Code. When the gas logs are operated with the damper open, non-combustible material and minimum mantel requirements do not apply.

# MOUNTING INTO A FIREPLACE OR FIREBOX

- Turn off the gas supply to the fireplace or firebox.
- Seal any fresh air vents and/or ash clean-out doors located on the floor or wall of the fireplace. If left unsealed, drafting may cause pilot outage or sooting. Use a heat resistant sealant. Do not seal the chimney flue damper.

Before installing in a solid fuel burning fireplace, the chimney flue and firebox must be cleaned of soot, creosote, ashes and loose paint by a qualified chimney cleaner.

**You must secure the gas log heater to the fireplace floor. If not, the entire unit may move when you adjust the controls. Movement of unit may cause shifting of the gas logs which leads to sooting and improper burning. Grate movement could cause a gas leak.**

**Special care is required if you are installing the unit into a sunken fireplace. You must raise the fireplace floor to allow access to gas log controls. This will insure adequate air flow and guard against sooting. Raise the fireplace floor using noncombustible materials.**

**Assembly Procedure:**

1. Center the gas log unit in the fireplace or firebox. Make certain the front feet of the grate sit inside the front edge of the fireplace or firebox.
2. An anchor hole is provided in the two bottom side members of the grate frame. After centering the grate correctly, mark the hole positions on the fireplace/firebox floor. Drill three 5/32" diameter holes approximately 1-1/2" deep for masonry screws or three 1/8" holes for sheet metal screws.

**NOTICE: Do not use the mounting hole underneath the pilot. Installing a screw there may damage the pilot.**

3. Anchor the grate to the fireplace/firebox floor using the screws provided. Refer to **Figure 12**.

**Proper installation of the grate is essential to prevent any movement of the gas logs and controls during operation.**

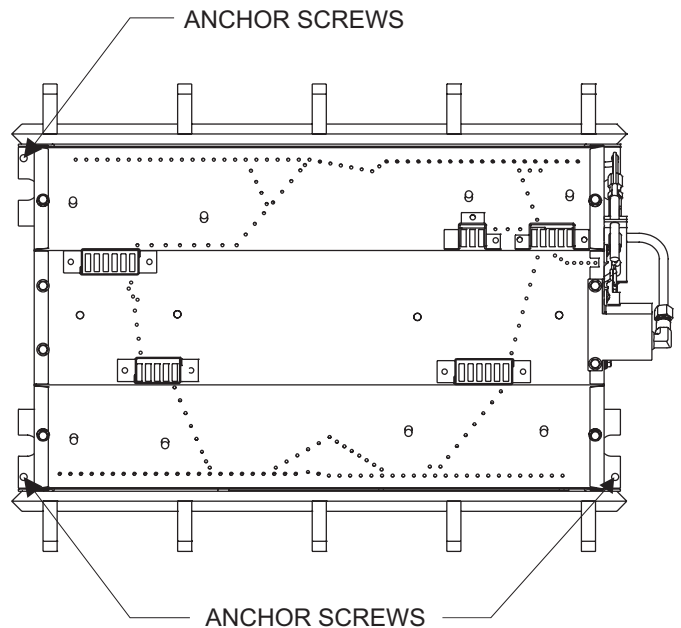

Figure 12



# GAS SUPPLY

Check all local codes for requirements, especially for the size and type of gas supply line required.

RECOMMENDED GAS PIPE DIAMETER				
Pipe Length	Schedule 40 Pipe Inside Diameter		Tubing, Type L Outside Diameter	
	Natural	Propane	Natural	Propane
0-10 feet 0-3 meters	1/2" 12.7mm	3/8" 9.5mm	1/2" 12.7mm	3/8" 9.5mm
10-40 feet 4-12 meters	1/2" 12.7mm	1/2" 12.7mm	5/8" 15.9mm	1/2" 12.7mm
40-100 feet 13-30 meters	1/2" 12.7mm	1/2" 12.7mm	3/4" 19mm	1/2" 12.7mm
100-150 feet 31-46 meters	3/4" 19mm	1/2" 12.7mm	7/8" 22.2mm	3/4" 19mm

**NOTICE:** Never use plastic pipe. Check to confirm whether your local codes allow copper tubing or galvanized.

**NOTICE:** Since some municipalities have additional local codes, it is always best to consult your local authority and installation code.

## Installing a New Main Gas Shut-Off

Each appliance should have its own manual gas shut-off.

A manual main gas shut-off should be located in the vicinity of the unit. Where none exists, or where its size or location is not adequate, contact your local authorized installer for installation or relocation.

Compounds used on threaded joints of gas piping shall be resistant to the action of liquefied petroleum gases. The gas lines must be checked for leaks by the installer. This should be done with a soap solution watching for bubbles on all exposed connections, and if unexposed, a pressure test should be made.

**NOTICE:** Check inlet and outlet fittings on gas valve for leaks, but do not expose electronic components to the solution. Exposing them to the solution may damage the components.

**Never use an exposed flame to check for leaks. Appliance must be disconnected from piping at inlet of control valve and pipe capped or plugged for pressure test. Never pressure test with appliance connected; control valve will sustain damage!**

A gas valve and ground joint union should be installed in the gas line upstream of the gas control to aid in servicing. It is required by the National Fuel Gas Code that a drip line be installed near the gas inlet. This should consist of a vertical length of pipe tee connected into the gas line that is capped on the bottom in which condensation and foreign particles may collect.

## FLEXIBLE GAS LINE CONNECTION

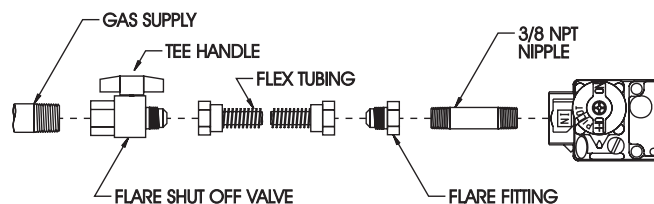

## RIGID GAS LINE CONNECTION

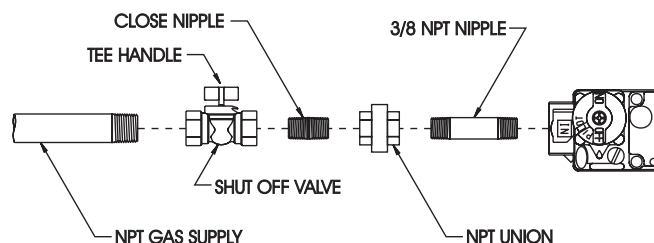

Figure 13

The use of the following gas connectors is recommended:

- ANS Z21.24 Appliance Connectors of Corrugated Metal Tubing and Fittings
- ANS Z21.45 Assembled Flexible Appliance Connectors of Other Than All-Metal Construction

The above connectors may be used if acceptable by the authority having jurisdiction. The Commonwealth of Massachusetts requires that a flexible appliance connector cannot exceed three feet in length.

## Pressure Testing of the Gas Supply System

1. To check the inlet pressure to the gas valve, a 1/8" (3.175mm) N.P.T. plugged tapping, accessible for test gauge connection, must be placed immediately upstream of the gas supply connection to the appliance.
2. The appliance and its individual shut-off valve must be disconnected from the gas supply piping system during any pressure testing of that system at test pressures in excess of 1/2 psig (3.5 kPa).
3. The appliance must be isolated from the gas supply piping system by closing its individual manual shut-off valve during any pressure testing of the gas supply piping system at test pressures equal to or less than 1/2 psig (3.5 kPa).

**ATTENTION!** If one of the procedures results in pressures in excess of 1/2 psig (14" w.c.) (3.5 kPa) on the appliance gas valve, it will result in a hazardous condition.

# PLACEMENT OF GLOWING EMBERS AND LAVA ROCK

Light coverage of the glowing embers (rockwool) will provide the best result. Separate the rockwool by hand and make your coverage as light and fluffy as possible. Place just enough rockwool on the burner to obtain a glow and yellow-tipped flame. Do ensure that the carry-over ports between the large flame ports have coverage.

**Do not place rockwool over large ports in middle portion of burner.**

**Rockwool should not be placed in the area of the pilot assembly.**

Application of excess rockwool may adversely affect performance of the burner.

## ⚠ WARNING

**All previously applied rockwool must be removed prior to reapplication.**

Over time, the rockwool will break down and new rockwool will need to be placed to recreate the original glowing embers effect. Remove all old rockwool from the appliance and apply new rock as described in this section or the log manual.

**NOTICE:** Only the rockwool supplied with this unit or ordered in accordance with the Parts List on pages 38 and 40 should be used on this burner. See the Parts List on pages 32 and 34 to order replacement rockwool.

## Placing Lava Rock in Front of Burner on Fireplace Floor

Spread lava rocks on fireplace floor in front and sides of the burner pan. Lava rocks can be placed around the VFSUE control module. The lava rocks are for decorative effect and are not required for fireplace operation.

**ATTENTION:** Do not place lava rocks on burner, logs or rockwool. The lava rocks should only be placed on the fireplace floor.

# OPERATION INSTRUCTIONS/FLAME APPEARANCE

Flames from the pilot (rear right back side of the pan burner) as well as the main flame should be visually checked as the log set is installed.

In normal operation at full rate after 10 to 15 minutes, the flame appearance should be sets of yellow flames.

**NOTICE:** All flames will be random by design, flame height will go up and down.

Glowing embers (rockwool) can cover the pan burner's round ports in between the front and middle logs, but very little is necessary to cover this area. Excess ember material causes the yellow flame to become orange and stringy. Apply just enough to obtain slow glow and a gold yellow flame.

Avoid any drafts that alter burner flame patterns. Do not allow fans to blow directly into fireplace. Do not place a blower inside the burner area of the firebox. Ceiling fans may create drafts that alter flame patterns. Sooting and improper burning will result.

During manufacturing, fabricating and shipping, various components of this appliance are treated with certain oils, films or bonding agents. These chemicals are not harmful, but may produce annoying smoke and smells as they are burned off during the initial operation of the appliance, possibly causing headaches or eye or lung irritation. This is a normal and temporary occurrence.

The initial break-in operation should last 2-3 hours with the burner at the highest setting. Provide maximum ventilation by opening windows or doors to allow odors to dissipate. Any odors remaining after this initial break-in will be slight and will disappear with continued use.

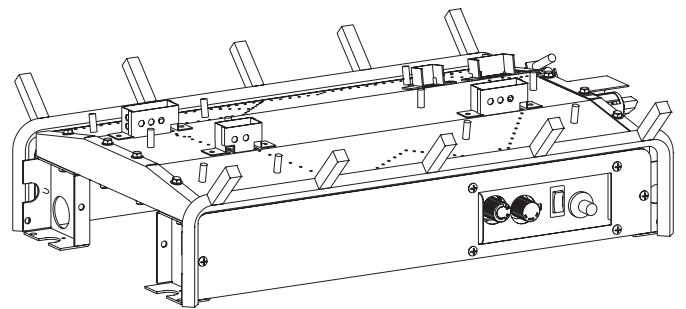

VFSUR - Figure 14

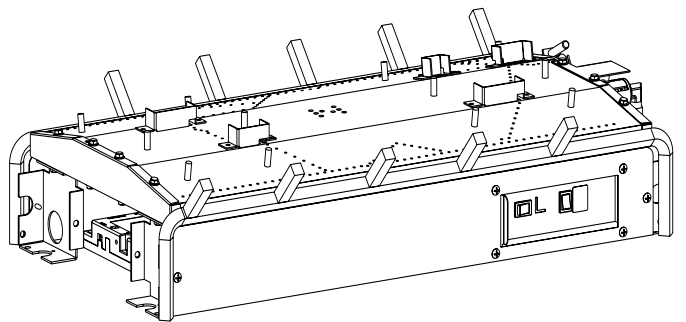

VFSUE - Figure 15

## Note For Burner Port Ignition:

Due to the size of the burner, there may be a small delay before all burner ports ignite.

# VFSUR(18,24,30) LIGHTING INSTRUCTIONS



## FOR YOUR SAFETY READ BEFORE LIGHTING

### ⚠ WARNING

If you do not follow these instructions exactly, a fire or explosion may result causing property damage, personal injury or loss of life.

- A. This appliance has a pilot which must be lighted by hand. When lighting the pilot, follow these instructions exactly.
- B. **BEFORE LIGHTING**, smell all around the appliance area for gas. Be sure to smell next to the floor because some gas is heavier than air and will settle on the floor.
- WHAT TO DO IF YOU SMELL GAS**
- Do not try to light any appliance.
  - Do not touch any electrical switch; Do not use any phone in your building.
  - Immediately call your gas supplier from a neighbor's phone. Follow the gas supplier's instructions.
  - If you cannot reach your gas supplier, call the fire department.
- C. Use only your hand to push in or turn the gas control knob. Never use tools. If the knob will not push in or turn by hand, don't try to repair it, call a qualified service technician. Force or attempted repair may result in a fire or explosion.
- D. Do not use this appliance if any part has been under water. Immediately call a qualified service technician to inspect the appliance and to replace any part of the control system and any gas control which has been under water.

## LIGHTING INSTRUCTIONS

1. STOP! Read the safety information above on this page.
2. Open bottom louver assembly (if applicable).
3. Set REMOTE/OFF/ON switch to "OFF".
4. Turn off all electric power to the appliance (if applicable).
5. Push in gas control knob slightly and turn clockwise  to "OFF".  
NOTE: Knob cannot be turned from "PILOT" to "OFF" unless knob is pushed in slightly. Do not force.
6. Wait ten (10) minutes to clear out any gas. Then smell for gas, including near the floor. If you smell gas, STOP! Follow "B" in the safety information above. If you do not smell gas, go to the next step.
7. Find pilot - Follow metal tube from gas control. The pilot is located next to the burner, near the right side.
8. Turn gas control knob counterclockwise  to "PILOT".
9. Push in control knob all the way and hold in. Repeatedly push the Piezo Ignitor Button until the pilot is lit. Continue to hold the control knob in for about one (1) minute after the pilot is lit. Release knob, and it will pop back up. Pilot should remain lit. If it goes out, repeat steps 5 through 9.
  - If knob does not pop up when released, STOP and IMMEDIATELY call a qualified service technician or gas supplier.
  - If the pilot will not stay lit after several tries, turn the gas control knob to "OFF" and call your service technician or gas supplier.
10. Turn gas control knob counterclockwise  to "ON".
11. Set REMOTE/OFF/ON switch to desired setting.
12. Turn on all electric power to the appliance (if applicable).
13. Close bottom louver assembly (if applicable).

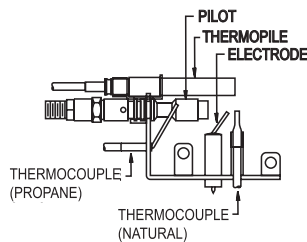
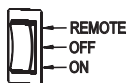
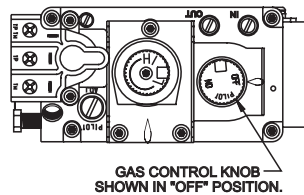

## TO TURN OFF GAS TO APPLIANCE

1. Open bottom louver assembly (if applicable).
2. Set REMOTE/OFF/ON switch to OFF.
3. Turn off all electric power to the appliance if service is to be performed (if applicable).
4. Push in gas control knob slightly and turn clockwise  to "OFF". Do not force.
5. Close bottom louver assembly (if applicable).

# VFSUR WIRING

Thermostats are not approved on vented decorative appliances.

Label all wires prior to disconnection when servicing controls. Wiring errors can cause improper and dangerous operation. Verify proper operation after servicing.

The millivolt gas valve does not require 24 or 110 volts. The gas valve is powered by the thermopile. See Figure 15 to provide optional wall switch, thermostat, or remote control. Maximum length of 20 feet of 16 AWG to conductor wires is to be used with all optional switches.

Use the red and green leads from the rocker switch that are wire nipped together to attach optional components.

## Check System Operation

Millivolt system and all individual components may be checked with a millivolt meter 0-1000 MV range.

## Remote Receiver -VFSUR-(18, 24, 30)

Use the following steps to place the **remote receiver** adjacent to the gas valve.

### ATTENTION:

1. The remote receiver can not be placed behind the gas valve and burner assembly.
2. When facing the appliance, the remote receiver must be placed to the **right** of the gas valve and burner assembly.

**NOTICE:** Do not let remote control receiver come in contact with burner assembly.

On circulating vent-free firebox, install remote control receiver behind bottom louver.

Refer to remote control installation and operating instructions for more details on remote control.

## 750 Millivolt System

When you ignite the pilot, the thermocouple produces millivolts (electrical current) which energizes the magnet in the gas valve. After 30 seconds to 1 minute time period you can release the gas control knob and the pilot will stay ON. Allow your pilot flame to operate an additional one (1) to two (2) minutes before you turn the gas control knob from the PILOT position to the ON position. This time period allows the millivolts (electrical current) to buildup to a sufficient level allowing the gas control to operate properly.

## Millivolt Control

The valve regulator controls the burner pressure which should be checked at the pressure test point. Turn captured screw counter clockwise 2 or 3 turns and then place tubing to pressure gauge over test point (Use test point "out" closest to control knob). After taking pressure reading, be sure and turn captured screw clockwise firmly to re-seal. Do not over torque. Check for gas leaks.

VFSUR Wiring Diagram

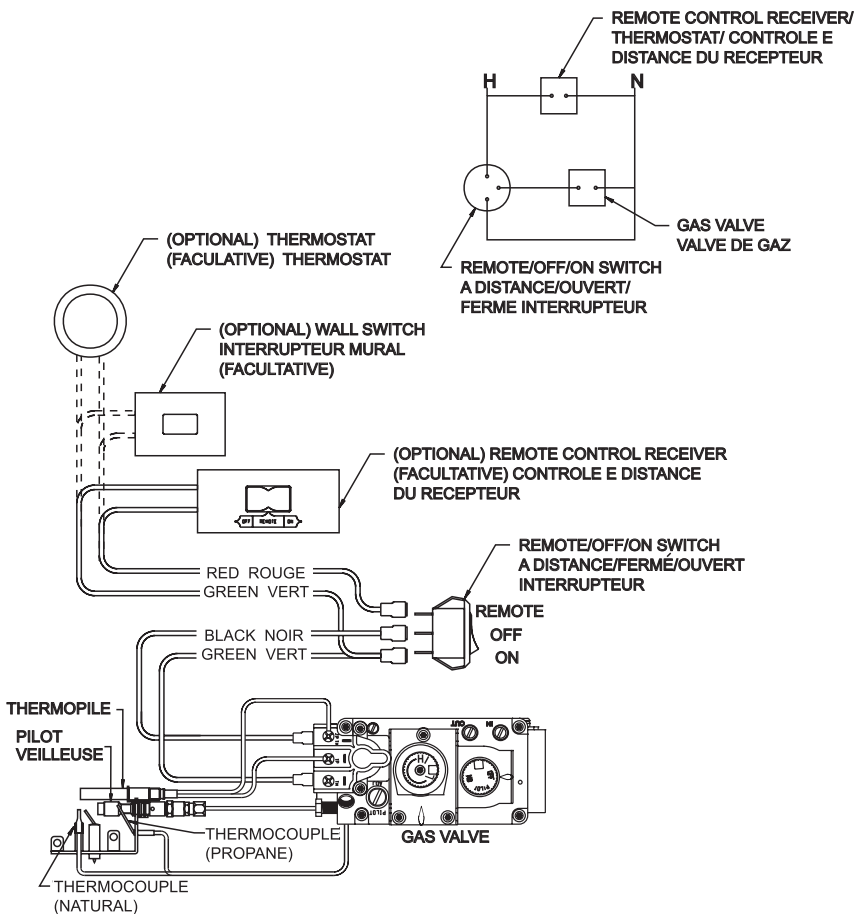

Figure 16

Valve View for Operating Sequence

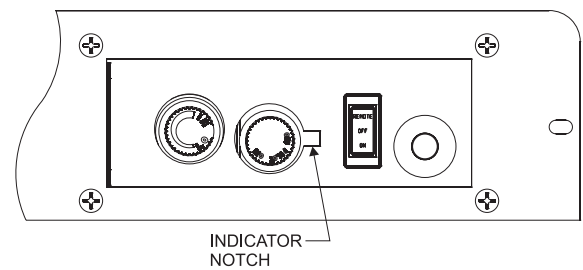

Figure 17

# VFSUR TROUBLESHOOTING

## SYMPTOMS - POSSIBLE CAUSES AND CORRECTION

1. **When ignitor button is pressed, there is no spark at ODS/pilot.**
  - a. Ignitor electrode positioned wrong - Replace pilot.
  - b. Ignitor electrode is broken - Replace pilot.
  - c. Ignitor electrode not connected to ignitor cable - Reconnect ignitor cable.
  - d. Ignitor cable pinched or wet. Keep ignitor cable dry - Free ignitor cable if pinched by any metal or tubing.
  - e. Broken ignitor cable - Replace ignitor cable.
  - f. Bad piezo ignitor - Replace piezo ignitor.
2. **Appliance produces unwanted odors.**
  - a. Appliance burning vapors from paint, hair spray, glues, etc. - Ventilate room. Stop using odor causing products while heater is running.
  - b. Gas leak - Locate and correct all leaks.
3. **Appliance shuts off during use. (Pilot and main burner are off.)**
  - a. Not enough fresh air is available for ODS/pilot to operate - Open window and/or door for ventilation.
  - b. Low line pressure - Contact local gas company.
  - c. ODS/pilot is partially clogged - Clean ODS/pilot.
  - d. Defective thermocouple - Replace pilot.
4. **Appliance shuts off during use. (Pilot stays on.)**
  - a. Low line pressure - Check line pressure to the valve.
  - b. Defective thermopile - Check pilot flame, check wire connections, output should be a minimum of 325 millivolts across. TH/TP and TP terminals with ON/OFF/REMOTE switch off.
5. **Gas odor even when control knob is in OFF position.**
  - a. Gas leak - Locate and correct all leaks.
  - b. Control valve defective - Replace control valve.
6. **When ignitor button is pressed, there is spark at ODS/pilot, but no ignition.**
  - a. Gas supply turned off or manual shut-off valve closed - Turn on gas supply or open manual shut-off valve.
  - b. Control knob not in PILOT position - Turn control knob to PILOT position.
  - c. Control knob not pressed in while in PILOT position - Press in control knob while in PILOT position.
  - d. Air in gas lines when installed - Continue holding down control knob. Repeat igniting operation until air is removed.
  - e. ODS/pilot is clogged - Replace ODS/pilot assembly or get it serviced.
  - f. Gas regulator setting is not correct - Replace gas regulator.
7. **ODS/pilot lights but flame goes out when control knob is released.**
  - a. Control knob not fully pressed in - Press in control knob fully.
  - b. Control knob not pressed in long enough - After ODS/pilot lights, keep control knob pressed in 30 seconds.
  - c. Manual shut-off valve not fully open - Fully open manual shut-off valve.
  - d. Thermocouple connection loose at control valve - Hand tighten until snug, then tighten 1/4 turn more.
  - e. Pilot flame not touching thermocouple, which allows thermocouple to cool, causing pilot flame to go out. This problem could be caused by either low gas pressure or dirty or partially clogged ODS/pilot - Contact local gas company.
  - f. Thermocouple damaged - Replace thermocouple.
  - g. Control valve damaged - Replace control valve.
8. **Burner does not light after ODS/pilot is lit.**
  - a. Burner orifice clogged - Clean burner or replace main burner orifice.
  - b. Burner orifice diameter is too small - Replace burner orifice.
  - c. Inlet gas pressure is too low - Contact qualified service person.
9. **If burning at main burner orifice occurs (a loud, roaring blow torch noise).**
  - a. You must turn off burner assembly and contact a qualified service person.
  - b. Manifold pressure is too low - Contact local gas company.
  - c. Burner orifice clogged - Clean burner or replace burner orifice.
10. **Logs appear to smoke after initial operation.**
  - a. Vapors from paint or curing process of logs - Problem will stop after a few hours of operation. Run the heater with the damper open if you have one, or open a window for the first few hours.  
Log heater is intended to be smokeless. Turn OFF heater and call qualified service person.
11. **Heater produces a whistling noise when main burner is lit.**
  - a. Turning control knob to HIGH position when main burner is cold - Turn control knob to LOW position and let warm up for a minute.
  - b. Air in gas line - Operate burner until air is removed from line. Have gas line checked by local gas company.
  - c. Dirty or partially clogged burner orifice - Clean burner or replace burner orifice.
12. **No gas to pilot.**
  - a. Propane-regulator shut down due to inlet pressure too high - Verify propane tank regulator is installed and set at 11" to 13" w.c. Replace regulator on heater.

If the gas quality is bad, your pilot may not stay lit, the burners may produce soot and the heater may backfire when lit. If the gas quality or pressure is low, contact your local gas supplier immediately.

# VFSUE(18,24,30) LIGHTING INSTRUCTIONS

## FOR YOUR SAFETY READ BEFORE LIGHTING

- A. BEFORE LIGHTING smell all around the appliance area for gas. Be sure to smell next to the floor because some gas is heavier than air and will settle on the floor.
- WHAT TO DO IF YOU SMELL GAS**
- Do not try to light any appliance.
  - Do not touch any electrical switch; do not use any phone in your building.
  - Immediately call your gas supplier from a neighbor's phone. Follow the gas supplier's instructions.
  - If you can't reach your gas supplier, call the fire department.
- B. If this appliance malfunctions, do not try to repair it, call a qualified service technician. Force or attempted repair may result in a fire or explosion.
- C. Do not use this appliance if any part has been under water. Immediately call a qualified service technician to inspect the appliance and to replace any part of the control system and any gas control which has been under water.

## LIGHTING INSTRUCTIONS

1. **STOP!** Read the safety information above.
2. Make sure that fresh batteries have been installed in the Battery Holder and Remote. (See Instruction Manual.)
3. Make sure that the Remote has been Learned to the Module. (See Page 23.)

### FOR OPERATION BY REMOTE:

1. Set "ON / OFF OR REMOTE" Switch to "OFF OR REMOTE"
2. Press the "ON" button on the Remote.
3. The Pilot Electrode will begin to spark (the ignition trial period will last up to 60 seconds).
4. The Pilot should light, and after flame has been sensed by the Thermocouple, the Burner will ignite.
5. The Burner will default to "HIGH" flame for five seconds before the flame height may be controlled by the remote. (See Page 23.)

### FOR OPERATION WITHOUT REMOTE:

1. Set "ON / OFF OR REMOTE" Switch to "ON"
3. The Pilot Electrode will begin to spark (the ignition trial period will last up to 60 seconds).
4. The Pilot should light, and after flame has been sensed by the Thermocouple, the Burner will ignite.
5. The Burner will default to "HIGH" flame, when operated without remote,

6. Burner can be turned off with "ON / OFF OR REMOTE" Switch.

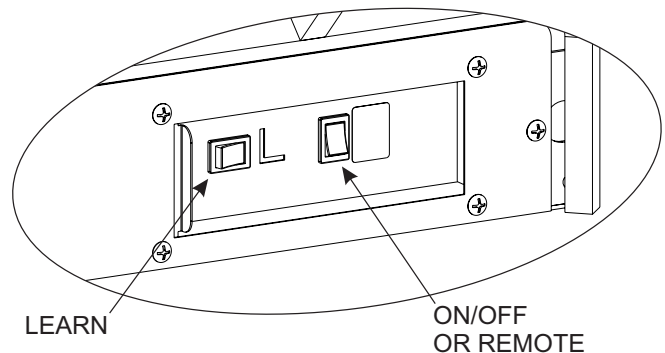

## TURN OFF GAS TO APPLIANCE

1. Turn Remote to "OFF" OR turn "ON / OFF OR REMOTE" Switch to "OFF OR REMOTE."

### **⚠ WARNING**

Improper installation, adjustment, alteration, service or maintenance can cause property damage, personal injury, or loss of life. Refer to the owner's information manual provided with this appliance. Installation and service must be performed by a qualified installer, service agency or the gas supplier. Keep burner and control compartment clean. See installation and operating instructions accompanying heater. This heater shall not be installed in a bedroom, bathroom, alcove or closet. Removal of this marking will void the compliance of this heater with ANSI Z21.60.

# VFSUE WIRING DIAGRAM

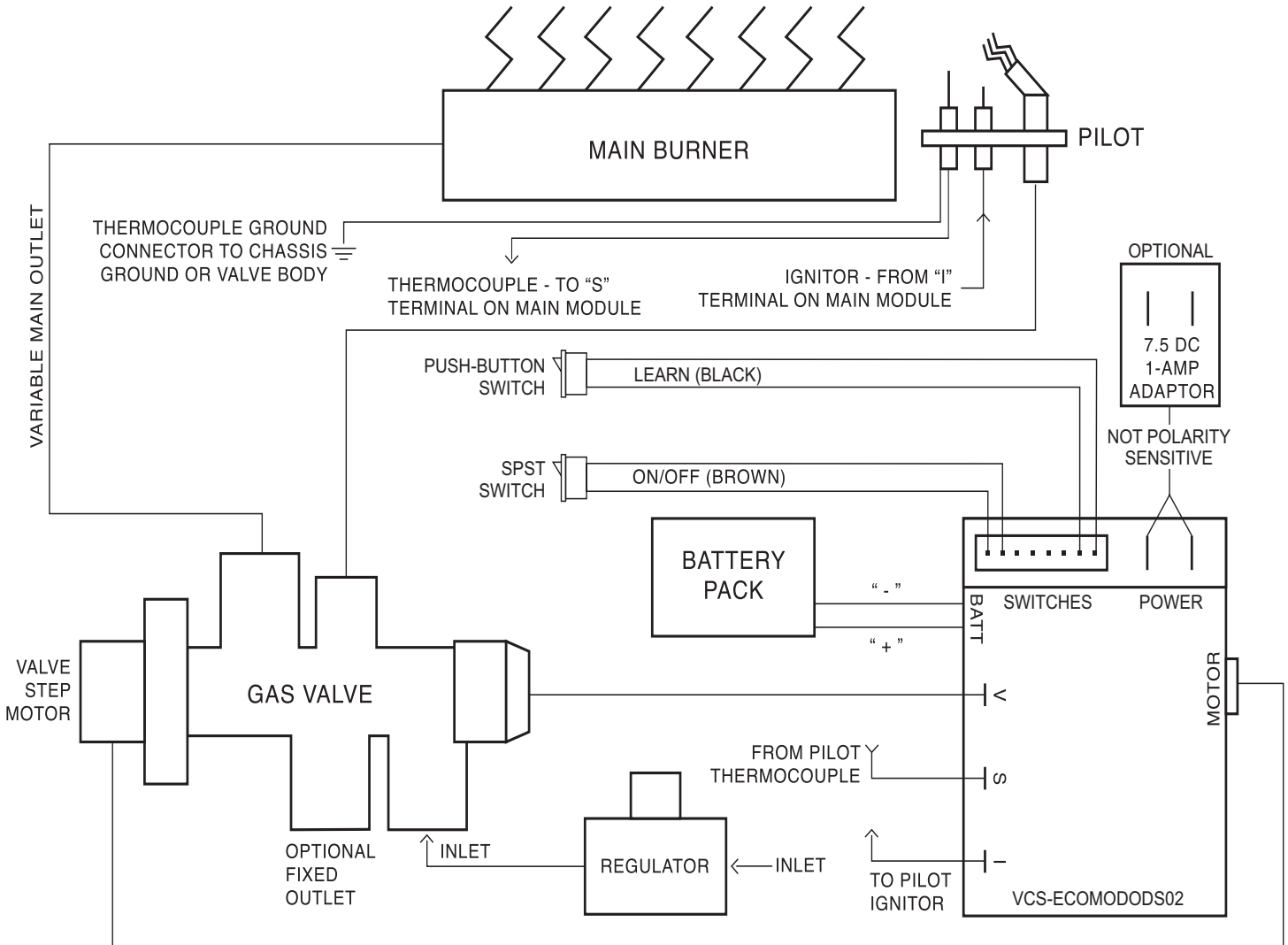

**Wiring Diagram  
Figure 18**

**NOTE:** Place battery pack in right rear corner of firebox. Energizer Lithium batteries are recommended for replacement. They will give 50% more service life as compared to Alkaline batteries.

# VFSUE REMOTE CONTROL INSTRUCTIONS

IF YOU CANNOT READ OR UNDERSTAND THESE INSTALLATION INSTRUCTIONS **DO NOT** ATTEMPT TO OPERATE

## INTRODUCTION

This transmitter operating range is approximately 20-feet. The transmitter operates on one of 1,048,576 security codes that are programmed into the transmitter at the factory; this transmitter operates on radio frequencies with non-directional signals. The receiver for this transmitter is built into the Control Module.

## TRANSMITTER

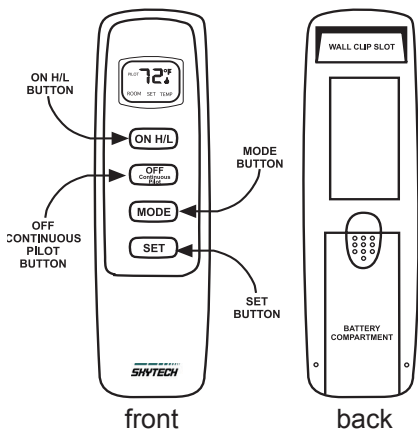

The transmitter operates on (2) 1.5V AAA batteries. It is recommended that ALKALINE batteries always be used for longer battery life and maximum operational performance.

Before using the transmitter, install the (2) AAA transmitter batteries into the battery compartment. (Use caution that batteries are installed in the proper direction)

## KEY SETTINGS

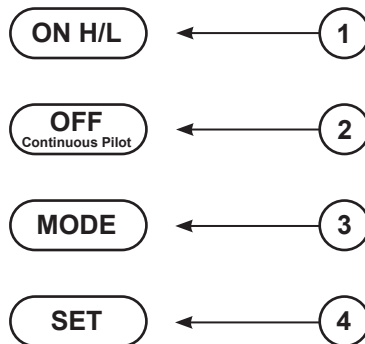

1. **ON H/L** ..... Turns unit to ON and operates the flame control HI or LO.
2. **OFF** ..... Shuts the unit OFF and activates the **Continuous Pilot** continuous pilot on feature.
3. **MODE** ..... Changes unit from manual mode to thermo mode.
4. **SET** ..... Sets temperature in thermo mode.

## LCD - LIQUID CRYSTAL DISPLAY

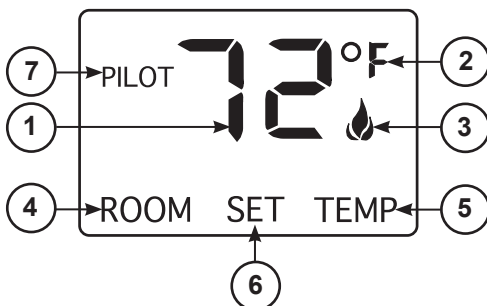

1. **DISPLAY** ..... Indicates CURRENT room temperature .
2. **° F OR ° C** ..... Indicates degrees Fahrenheit or Celsius.
3. **FLAME** ..... Indicates burner/valve in operation.
4. **ROOM** ..... Indicates remote is in THERMO operation.
5. **TEMP** ..... Appears during manual operation.
6. **SET** ..... Appears while setting the desired temperature in the thermo operation.
7. **PILOT** ..... Appears in the Continuous Pilot mode.



# VFSUE REMOTE CONTROL INSTRUCTIONS (CONT'D)

## SETTING ° F / ° C SCALE

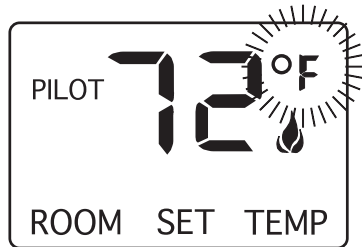

The factory setting for temperature is ° F. To change this setting to ° C, first

- Press the ON H/L key and the OFF Continuous Pilot key on the transmitter at the same time. This will change from ° F to ° C. Follow this same procedure to change from ° C back to ° F.

## MANUAL FUNCTION

To operate the system in the manual "MODE" do the following.

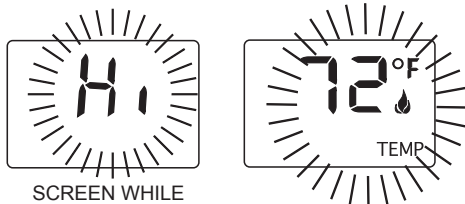

SCREEN WHILE PRESSING H/L KEY (IF PREVIOUS PRESS DISPLAYED "Lo" OR IF UNIT WAS OFF)

SCREEN AFTER 3 SECOND DEFAULT

### ON – HIGH FLAME OPERATION

Press and release the ON H/L key. The burner will come ON and flame will default to "Hi".

When the ON H/L key is pressed, the LCD screen will show Hi. After 3 seconds the LCD screen will default to display room temperature and the word TEMP will show. **(Flame icon will appear on the LCD screen while burner is ON.)**

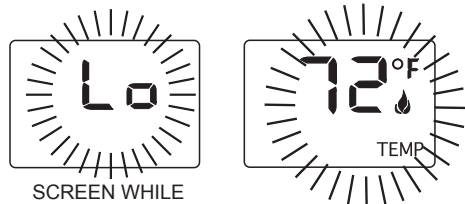

SCREEN WHILE PRESSING H/L KEY (IF PREVIOUS PRESS DISPLAYED "Hi")

SCREEN AFTER 3 SECOND DEFAULT

### ON – LOWERING FLAME HEIGHT FROM HIGH TO LOW

Press and hold the ON H/L key. The burner will stay ON and flame will descend to "Lo". A flame height between "Hi" and "Lo" can be selected by releasing the ON H/L key at any point between "Hi" and "Lo."

During this time the LCD screen will show Lo, after 3 seconds the LCD screen will default to display room temperature and the word TEMP will show. **(Flame icon will appear on the LCD screen while burner is ON.)**

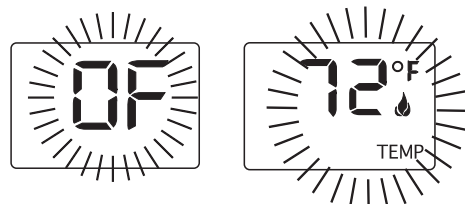

SCREEN WHILE PRESSING OFF KEY

SCREEN AFTER 3 SECOND DEFAULT

### ON – RAISING FLAME HEIGHT FROM LOW TO HIGH

Press and hold the ON H/L key. The burner will stay ON and flame will ascend to "Hi". A flame height between "Lo" and "Hi" can be selected by releasing the ON H/L key at any point between "Lo" and "Hi."

During this time the LCD screen will show Hi. After 3 seconds the LCD screen will default to display room temperature and the word TEMP will show. **(Flame icon will appear on the LCD screen while burner is ON.)**

**NOTE: The ON H/L key will send either a "Hi" or "Lo" signal based upon the previous command displayed. If the previous command was "Lo," the next will be "Hi," and vice-versa.**

# VFSUE REMOTE CONTROL INSTRUCTIONS (CONT'D)

## OFF OPERATION



SCREEN WHILE  
PRESSING OFF KEY

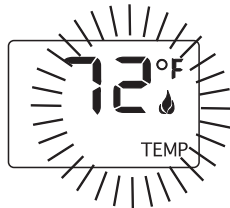

SCREEN AFTER 3  
SECOND DEFAULT

Press the OFF Continuous Pilot key. The screen will show OF and the burner will shut off. After 3 seconds the LCD screen will default to display room temperature and the word "TEMP" will also show on the screen. (Flame icon will not appear on the LCD screen in OFF mode)

## THERMOSTAT FUNCTION - SETTING DESIRED ROOM TEMPERATURE

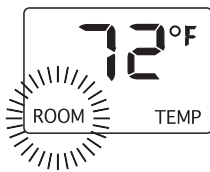

SCREEN WHILE  
DEPRESSING  
MODE KEY

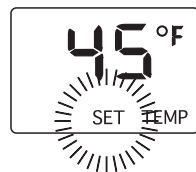

SCREEN WHILE  
DEPRESSING  
SET KEY

This remote control system can be thermostatically controlled when the transmitter is in the THERMO mode. To set the THERMO MODE and DESIRED room temperature, press the MODE key until the LCD screen shows the word ROOM, then the remote is in the thermostatic mode.

**NOTE: When the word ROOM is displayed on the screen the transmitter is in the thermo mode.**

## CHANGING SET TEMPERATURE & DISENGAGING THERMO MODE



SCREEN AT  
LOWEST THERMO  
SETTING



SCREEN AT  
HIGHEST THERMO  
SETTING

### TO CHANGE THE SET TEMPERATURE

Press and hold the SET key until the desired set temperature is reached. (By pressing and holding the set key the LCD screen set numbers will increase from 450 to 990 then restart over at 450) Next release the SET key. The LCD screen will display the set temperature for 3 seconds, then will flash the set temperature for 3 seconds, then the LCD screen will default to display the room temperature.

### TO DISENGAGE THERMO MODE

Press and release the MODE key or press the OFF Continuous Pilot key to disengage the thermo mode. The word ROOM on the LCD screen will not show when the thermo is not in operation.



SCREEN IN THE  
THERMO "ON"  
MODE

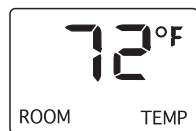

SCREEN IN THE  
THERMO "OFF"  
MODE

**NOTE: The highest SET temperature is 990 Fahrenheit (320 Celsius) and the lowest temperature is (450 Fahrenheit (60 Celsius).**

# VFSUE REMOTE CONTROL INSTRUCTIONS (CONT'D)

## CONTINUOUS PILOT FEATURE

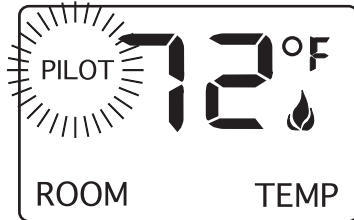

SCREEN IN THE  
CONTINUOUS PILOT  
MODE

This feature allows you to change from a spark to pilot system to a standing pilot system for appliances during Cold Climate to keep the firebox warm.

To operate the CONTINUOUS PILOT FEATURE do the following.

### ON OR OFF OPERATION

Press and hold the OFF CONTINUOUS PILOT key for approximately 5 seconds, until the word "PILOT" appears on the LCD screen.

**NOTE: The word PILOT will appear on the LCD screen in ON mode)**

## CP - CHILDPROOF FEATURE



SCREEN IN  
THE "CP" MODE

This remote control includes a CHILDPROOF "LOCK-OUT" feature that allows the user to "LOCK-OUT" operation of the appliance, from the TRANSMITTER.

### SETTING "LOCK-OUT" -(CP)

- To activate the "LOCK-OUT" feature, press and hold the ON H/L key and the MODE key at the same time for 5 seconds. The letters CP will appear in the TEMP frame on the LCD screen.
- To disengage the "LOCK-OUT", press and hold the ON H/L key and the MODE key at the same time for 5 seconds and the letters CP will disappear from the LCD screen and the transmitter will return to its normal operating condition.
- To verify that transmitter is in the CP lock-out mode press any key and the LCD screen will show "CP"

**NOTE:** If the appliance is **already** operating in the ON or THERMO MODES, engaging the "LOCK-OUT" **will not** cancel the operating MODE. Engaging the "LOCK-OUT" prevents only the **manual operation of the TRANSMITTER**. If in the auto modes, the THERMO operation will continue to operate normally. To totally "LOCK-OUT" the operation of the TRANSMITTER'S operating signals; the transmitter's MODE must be set to OFF.

# VFSUE REMOTE CONTROL INSTRUCTIONS (CONT'D)

## OPERATIONAL NOTES:

The Thermo Feature on the transmitter operates the appliance whenever the ROOM TEMPERATURE varies a certain number of degrees from the SET TEMPERATURE. This variation is called the "SWING" or TEMPERATURE DIFFERENTIAL. The normal operating cycle of an appliance may be 2-4 times per hour depending on how well the room or home is insulated from the cold or drafts.

The factory setting for the "swing number" is 2. This represents a temperature variation of +/- 20 F (10 C) between SET temperature and ROOM temperature, which determines when the fireplace will be activated. This function is pre-set at the factory.

The transmitter has ON and OFF manual functions that are activated by pressing either button on the face of the transmitter. When a button on the transmitter is pressed the word ON or OF will appear on the LCD screen to show while the signal is being sent. Upon initial use, there may be a delay of three seconds before the remote receiver will respond to the transmitter. This is part of the system's design.

**NOTE:** The Control Module will only respond to the transmitter when the 2-position switch on the burner is set to the OFF/REMOTE position. If the system does not respond, see LEARNING TRANSMITTER TO MODULE or check the batteries.

## THERMO UPDATING FEATURE –TRANSMITTER – (T/S –TX)

This remote control has a THERMO UPDATING Feature built into its software. The THERMO UPDATING Feature operates in the following manner, but only in the THERMO MODE: The transmitter reads the ROOM temperature every 2 minutes checking the ROOM temperature against the SET temperature and then sends a signal to the receiver.

## THERMO- SAFETY FEATURE

There is a THERMO- SAFETY feature that is built into the receiver of the module. This feature is temperature- activated and provides an extra margin of safety when the module is operating where ambient temperatures exceed 150 ° F degrees inside the module case.

The THERMO-SAFETY feature, in the module, operates in the following manner, when the appliance is in operation. The module is thermally protected from extreme heat conditions. Heat can have negative effect on the operation of the module's microprocessors.

When the ambient temperature at the THERMISTOR, inside the module case, reaches 1500 F, the THERMISTOR will automatically shut the appliance down and the module will begin emitting a series of 2 "beeps", every 4 seconds. When the ambient temperature, at the module, drops between 1300 F and 1500 F, the user can reactivate the appliance by pushing the ON H/L key on the transmitter. The flame icon must display on the LCD screen. When the ON H/L key is pressed to ON, the THERMISTOR "resets" itself and the appliance will begin operating again. However, the "beeping" will continue, if the ambient temperature remains between 1300 F and 1500 F. This "beeping" alerts the user that the module should be checked.

When the temperature drops below 1300 F, the "beeping" will cease, providing the user has "reset" the THERMISTOR by pushing the ON H/L key to ON to operate the appliance. Allow sufficient time for the receiver to cool below 1300 F, and then press ON H/L key to stop beeping.

## LEARNING TRANSMITTER TO MODULE

Each transmitter uses a unique security code. It will be necessary to press the LEARN button on the burner to accept the transmitter security code upon initial use, if batteries are replaced, or if a replacement transmitter is purchased from your dealer or the factory. In order for the module to accept the transmitter security code, be sure the switch on the burner is in the OFF/REMOTE position; the module will not LEARN if the switch is in the ON position. When you release the LEARN button the module will emit an audible "beep".

After the module emits the beep press ANY button on the transmitter and release. The module will emit several beeps indicating that the transmitter's code has been accepted into the module.

The microprocessor that controls the security code matching procedure is controlled by a timing function. If you are unsuccessful in learning the security code on the first attempt, wait 1 - 2 minutes before trying again--this delay allows the microprocessor to reset its timer circuitry--and try up to two or three more times.

## BATTERY LIFE

Life expectancy of alkaline batteries in the SP1001H/LTH should be at least 12 months. Check and replace transmitter batteries annually. When the transmitter no longer operates the remote receiver from a distance it did previously (i.e., the transmitter's range has decreased) or the remote receiver does not function the transmitter batteries should be checked. The transmitter should operate with as little as 2.5 volts battery power.

## SPECIFICATIONS

**BATTERIES:** Transmitter (2) 1.5 volt AAA t bateries

Operating Frequency: 303.8 MHZ

FCC ID No.'s: transmitter - K9LSP1001TH

Canadian IC ID No.'s: transmitter – 2439A-SP1001TH

## FCC REQUIREMENTS

**NOTE: THE MANUFACTURER IS NOT RESPONSIBLE FOR ANY RADIO OR TV INTERFERENCE CAUSED BY UNAUTHORIZED MODIFICATIONS TO THIS EQUIPMENT. SUCH MODIFICATIONS COULD VOID THE USER'S AUTHORITY TO OPERATE THE EQUIPMENT.**

# VFSUE SWITCH OPERATION

**IF YOU CANNOT READ OR UNDERSTAND THESE INSTRUCTIONS DO NOT ATTEMPT TO OPERATE**

## **OPERATION**

1. In order to operate this appliance without the remote, the "ON/OFF OR REMOTE" switch must be set to "ON."
2. With the "ON/OFF OR REMOTE" switch set to "ON", the burner lighting sequence will initiate.
3. The flame height will default to high.
4. To turn the burner off, toggle the "ON/OFF OR REMOTE" switch away from the "ON" position.

# VFSUE CONTROL SYSTEM SPECIFICATIONS

## GENERAL CRITERIA:

- Main control module will control electronic pilot ignition, main burner ON/OFF operation, and Main Flame modulation.
- Main control module will also house an RF reception circuit.
- Manual operation of the system will be accomplished via the switch, allowing ON/OFF operation.
- Control can Learn up to 3 transmitter security codes (3-transmitter LEARN memory).

## FEATURES:

- **Manual Operation Capability**
  1. ON/OFF
- **Remote Operation Capability**
  1. Manual ON/OFF
  2. Continuously Variable Flame Modulation
- **Ignition Safety**
- **Recycle Safety**
- **Sensor Safety**
- **Thermal Safety**
- **Communication Safety**

## SPECIFICATIONS

- **Operating Power:**
  1. 6V Battery Power:
    - 4xAA Size – Intended for battery backup use.
    - Minimum operating voltage – 5.4VDC
- **Temperature Limit: 170-deg. F.**
- **RF Receiver Frequency: 303.8MHz**
- **Ignition Trial Period: 50-60 seconds**
- **Sense Voltage Thresholds (start with V-TC=0mV before taking threshold measurements):**
  1. Flame True = 12mV +/-1.5mV (judged while safety magnet is powered by control)
  2. TC-HOT (OK to transfer thermocouple power to Safety Magnet) = 18mV minimum, multiple samples taken every 5-seconds and compared with previous sample set, if change less than +0.5mV, TC-HOT=TRUE. Maximum allowable time control will power Safety Magnet = 60-seconds.
  3. Flame False (Before TC-HOT=TRUE) = 10mV +/-1.5mV
  4. Flame False (After TC-HOT=TRUE) = 10mV +5mV/-0mV
- **Maximum Flame Failure Response Time: 30-seconds, when used with approved fast-acting thermocouple.**
- **Minimum Flame Failure Response Time: 10-seconds**
  1. 10-Second Flame Failure Response Time Logic:
    - Main Burner is turned to ON.
    - Normal pilot ignition sequence occurs.
    - Thermocouple output reaches FLAME=TRUE threshold
    - Main Burner is Opened
    - At the same time the main burner is opened, a 10-second delay timer is started.
    - If the thermocouple voltage drops to below FLAME=FALSE during this 10-second timer period, THE MAIN BURNER SHALL REMAIN ON and THE CONTROL WILL EMIT THE IGNITION SPARK (follow normal sparking pattern).
    - If the thermocouple voltage recovers to above FLAME=TRUE during the 10-second timer period, the sparking will stop and normal operation will resume. However, the 10-second timer WILL NOT be reset. Furthermore, this event will NOT trigger the re-ignition safety fault counter.

- If the thermocouple voltage does not recover to above FLAME=TRUE after the 10-second timer period expires, the main flame will turn OFF and the control will attempt to re-establish the pilot flame again with the normal 60-second trial period. Furthermore, this event WILL trigger the re-ignition safety fault counter (3-attempts within 2-minutes).
- The 10-second delay timer will only be reset when the system is cycled to OFF, then to ON again.

- **Maximum Number of re-ignition attempts**

1. Automatic: 2 re-attempts within 2-minutes, 5-minute lockout
2. Manual: 5 re-attempts within 2-minutes, 5-minute lockout

- **Spark Pattern: Interrupted (2-second spark, 1-second sense window)**

- **Flame Modulation Settings:**

1. Remote operation – Continuously Variable
2. Low Flow Rate regulated by low rate set-screw in gas valve
3. Main flame shall default to HI setting for 5-seconds whenever turned ON before modulating to any other setting.

- **Connections:**

1. Valve Motor Connection: On-Board Plug-in for 7-pin Copreci supplied connector:
  - Pin 1 (to White): External Ground Reference
  - Pin 2 (to Green): Motor Constant Positive 1
  - Pin 3 (to Red): Negative Pulse 1
  - Pin 4 (to Blue): Negative Pulse 2
  - Pin 5 (to Green): Motor Constant Positive 2
  - Pin 6 (to Black): Negative Pulse 3
  - Pin 7 (to Yellow): Negative Pulse 4
  - Refer to Copreci supplied motor drawing (Saia-Burgess Drawing Number 4 753 4209 0 D) for additional details.
  - Labeled "MOTOR" (engraved on plastic case)
2. 8-Pin Wire Harness (part number VCS-ECO8P8W24WH) – Other variations may be specified separately.
  - ON-Board Plug-in for 8-pin wiring harness labeled "SWITCHES" (engraved on plastic case) with the following wiring:
    - \* ON/OFF Switch Wires: 24" Brown 22-AWG, 105-Deg. C terminating in ¼" female quick connect terminal with hard sleeve insulation (Tyco Electronics Ultra-Fast or similar) labeled "ON/OFF" (sticker applied to wire termination end).
    - \* High/Low Switch Wires: 24" Blue 22-AWG, 105-Deg. C terminating in ¼" female quick connect terminal with hard sleeve insulation (Tyco Electronics Ultra-Fast or similar) labeled "HI/LO" (sticker applied to wire termination end).
    - \* 2 yellow wires not used.
    - \* LEARN Switch Wires: 24" Black 22-AWG, 105-deg. C terminating in ¼" female quick connect terminal with hard sleeve insulation (Tyco Electronics Ultra-Fast or similar) (for connection to normally open momentary contact switch) labeled "LEARN" (sticker applied to wire termination end).

# VFSUE CONTROL SYSTEM SPECIFICATIONS (CONT'D)

1. Battery Pack Connection: On-Board Plug-in receptacle for 2-pin connector (JST XH 2.5mm wafer or equivalent) labeled "BATT" (engraved in plastic case).
2. Igniter Connection: Male On-Board Plug-in Spade for 0.110" quick connect; labeled "I" (engraved in plastic case).
3. Thermocouple Connection: Male On-Board Plug-in Spade for ¼" quick connect; labeled "S" (engraved in plastic case).
4. Valve Safety Operator Connection: Male On-Board Plug-in Spade for 3/16" quick connect; labeled "V" (engraved in plastic case).

## FUNCTIONAL DESCRIPTION

### Valve Operation

- **Magnetic Safety Operator:**
  1. Hold-In Current:  $\leq 150\text{mA}$
  2. Drop Out Current: 135-40mA
  3. Coil Resistance: 0.0155-Ohms  $\pm 10\%$
- **Motor Operator: 4-pole step motor, 700mA consumption**
- **Sequencing:**
  1. Pilot Ignition:
    - Drive step motor - Push Magnetic Safety Operator Open (physical stop at +600 steps; overdrive to ensure pushing operator open).
    - Hold Magnetic Safety Operator open with power from the control applied to the "V" terminal.
    - Drive step motor Steps - Open Secondary Pilot Gas Passageway.
    - Emit Ignition Spark & Prove Pilot Flame, and then remove power supplied by control from Magnetic Safety Operator; power is now supplied to Magnetic Safety Operator by thermocouple output.
  2. Main Flame On (High):
    - Drive step motor— Calibrate step motor (physical stop; overdrive to ensure "0" point calibration) and open main gas flow.
    - Drive step motor— Move to High flame.
  3. Continuously Variable Flame Modulation:
    - Step motor may be adjusted to any position between High flame setting and Low flame setting by either pressing and holding either the UP or DOWN flame setting buttons on a transmitter intended for use with this control.
  4. Low Flame: +210 steps from "0" point.
  5. OFF: Drive step motor— Move to OFF setting.

## SWITCH OPERATION

- **ON/OFF:**
  1. OFF Position (contacts open):
    - Control is idle waiting for ON/OFF switch state change or command from wireless remote control.
  2. ON Position (contacts closed):
    - Control will initiate the pilot ignition sequence.
    - Control will then default to Main Flame On (High)
    - Control will ignore commands from RF circuit (switch ON overrides remote control operation).

- **LEARN:**
  1. Press and release to open LEARN window, the control is ready to accept a transmitter security code.
  2. LEARN window will remain open for 60-seconds.
  3. Control will learn up to 3 different transmitter security codes.
  4. Security codes will be retained in EEPROM memory indefinitely if power is removed.
  5. Press and hold for 6-seconds to clear all transmitter security codes retained in memory.

## AUDIBLE ALERTS

- **LEARN Window Open:**
  1. Audible Alert: Single long beep (~1 second in length) after pushing the LEARN button.
  2. Description of Alert: Inform the user that the module is ready to learn the security code of a transmitter.
- **Code Accepted:**
  1. Audible Alert: Four short beeps (~0.2 seconds in length) in rapid succession.
  2. Description of Alert: Inform the user that the module has successfully learned a transmitter's security code.
- **LEARN Memory Cleared:**
  1. Audible Alert: Three long beeps in succession.
  2. Description of Alert: Inform user that the transmitter security code memory has been successfully cleared.

## ERROR CODES

- **Ignition Safety (Protection for Ignition system):**
  1. Error Code: One short beep (~0.2 seconds in length) every one-second.
  2. Description of Fault: Pilot is not successfully ignited within the trial period.
  3. Action: The control will operate the step motor in the gas valve to the OFF position.
  4. How to Clear: Press OFF button.
- **Recycle Safety: (Protection for Unstable Pilot)**
  1. Error Code: Two short beeps every one-second.
  2. Description of Fault:
    - Automatic Recycle - Pilot is proven and lost 3-times within 2-minutes without multiple ON/OFF commands.
    - Manual Recycle – Ignition sequence is initiated 6-times within 2-minutes.
  3. Action: The control will operate the step motor in the gas valve to the OFF position.
  4. How to Clear:
    - After 5-minutes has elapsed (5-minute internal timer expires), the module must see the mode/switch in the OFF position after that time.
    - Once the module see's the mode/switch in the OFF position after the 5-minutes has elapsed, it will stop beeping.
    - Once the beeping has stopped, it will accept normal operation including another ON command from the user.
    - The only other way to reset this fault in another manner is to remove power to the module (for approximately 30-seconds until the internal circuits discharge), and then re-apply power.

# VFSUE CONTROL SYSTEM SPECIFICATIONS (CONT'D)

- **Sensor Safety (Protection for Flame sensor):**
  1. Error Code: 4 Short beeps every one-second (Constant beeping)
  2. Description of Fault: Pilot flame sensor voltage is too high (>FLAME=FALSE threshold) when ignition sequence is initiated.
  3. Also occurs if ground circuit is not properly connected, including ground from pilot assembly or ground integral to valve's motor connection (motor not plugged into module or white wire on valve end of wire harness not connected to ground).
  4. Action: The control will operate the step motor in the gas valve to the OFF position.
  5. How to Clear: Press OFF button.
- **Thermal Safety (Overheat Protection):**
  1. Error Code: 4 Short beeps every 2-seconds.
  2. Description of Fault: Internal temperature has exceeded 170 deg. F.
  3. Action: The module will operate the step motor in the gas valve to the OFF position.
  4. How to Clear: Module's internal temperature must cool to below 160 deg. F and then press OFF button.
- **Communication Safety (NOTE: This feature is only available when transmitter includes an LCD screen).**
  1. Error Code: One short beep every 4-seconds
  2. Description of Fault: Transmitter and receiver are not communicating properly. Control monitors RF transmissions for communication safety signal (expected every 15-minutes). If the signal is not received within 15-minutes, a 2-hour countdown begins. If no other RF transmissions are received before the countdown expires, the control will enter Communication Safety fault.
  3. Action: The module will operate the step motor in the gas valve to the OFF position.
  4. How to Clear: Control must receive a subsequent RF transmission.



# VFSUE TROUBLESHOOTING SYMPTOMS - POSSIBLE CAUSES & CORRECTION

1. **When ignitor button is pressed, there is no spark at ODS/pilot.**
    - a. Ignitor electrode positioned wrong - Replace pilot.
    - b. Ignitor electrode is broken - Replace pilot.
    - c. Ignitor electrode not connected to ignitor cable - Reconnect ignitor cable.
    - d. Ignitor cable pinched or wet. Keep ignitor cable dry - Free ignitor cable if pinched by any metal or tubing.
    - e. Broken ignitor cable - Replace ignitor cable.
    - f. Bad piezo ignitor - Replace piezo ignitor.
  2. **Appliance produces unwanted odors.**
    - a. Appliance burning vapors from paint, hair spray, glues, etc. - Ventilate room. Stop using odor causing products while heater is running.
    - b. Gas leak - Locate and correct all leaks.
  3. **Appliance shuts off during use. (Pilot and main burner are off.)**
    - a. Not enough fresh air is available for ODS/pilot to operate - Open window and/or door for ventilation.
    - b. Low line pressure - Contact local gas company.
    - c. ODS/pilot is partially clogged - Clean ODS/pilot.
    - d. Defective thermocouple - Replace pilot.
  4. **Appliance shuts off during use. (Pilot stays on.)**
    - a. Low line pressure - Check line pressure to the valve.
  5. **Gas odor even when control knob is in OFF position.**
    - a. Gas leak - Locate and correct all leaks.
    - b. Control valve defective - Replace control valve.
  6. **When ignitor button is pressed, there is spark at ODS/pilot, but no ignition.**
    - a. Gas supply turned off or manual shut-off valve closed - Turn on gas supply or open manual shut-off valve.
    - b. Control knob not in PILOT position - Turn control knob to PILOT position.
    - c. Control knob not pressed in while in PILOT position - Press in control knob while in PILOT position.
    - d. Air in gas lines when installed - Continue holding down control knob. Repeat igniting operation until air is removed.
    - e. ODS/pilot is clogged - Replace ODS/pilot assembly or get it serviced.
    - g. Gas regulator setting is not correct - Replace gas regulator.
  7. **ODS/pilot lights but flame goes out when control knob is released.**
    - a. Control knob not fully pressed in - Press in control knob fully.
    - b. Control knob not pressed in long enough - After ODS/pilot lights, keep control knob pressed in 30 seconds.
    - c. Manual Shut-off valve not fully open - Fully open manual shut-off valve.
  - d. Thermocouple connection loose at control valve - Hand tighten until snug, then tighten 1/4 turn more.
  - e. Pilot flame not touching thermocouple, which allows thermocouple to cool, causing pilot flame to go out. This problem could be caused by either low gas pressure or dirty or partially clogged ODS/pilot - Contact local gas company.
  - f. Thermocouple damaged - Replace thermocouple.
  - g. Control valve damaged - Replace control valve.
8. **Burner does not light after ODS/pilot is lit.**
    - a. Burner orifice clogged - Clean burner or replace main burner orifice.
    - b. Burner orifice diameter is too small - Replace burner orifice.
    - c. Inlet gas pressure is too low - Contact qualified service person.
  9. **If burning at main burner orifice occurs (a loud, roaring blow torch noise).**
    - a. You must turn off burner assembly and contact a qualified service person.
    - b. Manifold pressure is too low - Contact local gas company.
    - c. Burner orifice clogged - Clean burner or replace burner orifice.
  10. **Logs appear to smoke after initial operation.**
    - a. Vapors from paint or curing process of logs - Problem will stop after a few hours of operation. Run the heater with the damper open if you have one, or open a window for the first few hours.  
Log heater is intended to be smokeless. Turn OFF heater and call qualified service person.
  11. **Heater produces a whistling noise when main burner is lit.**
    - a. Turning control knob to HIGH position when main burner is cold - Turn control knob to LOW position and let warm up for a minute.
    - b. Air in gas line - Operate burner until air is removed from line. Have gas line checked by local gas company.
    - c. Dirty or partially clogged burner orifice - Clean burner or replace burner orifice.
  12. **No gas to pilot.**
    - a. Propane-regulator shut down due to inlet pressure too high - Verify propane tank regulator is installed and set at 11" to 13" w.c. Replace regulator on heater.
  13. **Remote ignition is attempted, but only a long beeping sound is heard.**
    - a. ON/OFF switch is in the O "OFF" position.

If the gas quality is bad, your pilot may not stay lit, the burners may produce soot and the heater may backfire when lit. If the gas quality or pressure is low, contact your local gas supplier immediately.

# BURNER INSTRUCTIONS

Check the following items during installation prior to lighting the multisided burner:

- Check for correct air shutter.
  - **Natural Gas** - See Natural Gas air shutter table on page 5. Do not operate burner with incorrect air shutter.
  - **Propane Gas** - The air shutter setting must be Full Open for VFSU(R,E)(18,24,30).

AIR SHUTTER FULL OPEN

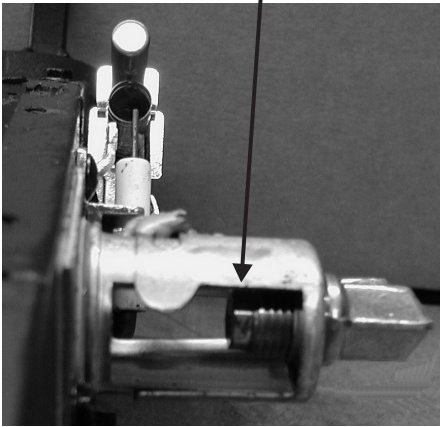

**NOTICE:** Orifice shield removed for photo clarity.

- Check all carryover ports for blockage from the ceramic media
  - If there is blockage, use a small pointed tool to move the ceramic media away from the carryover port.

BLOCKED CARRYOVER PORTS

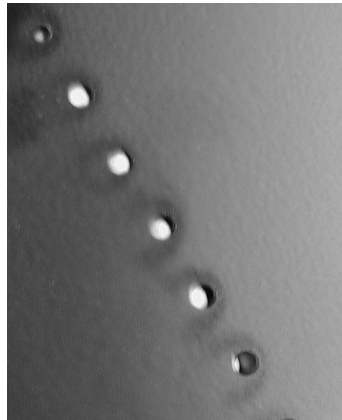

UNBLOCKED CARRYOVER PORTS

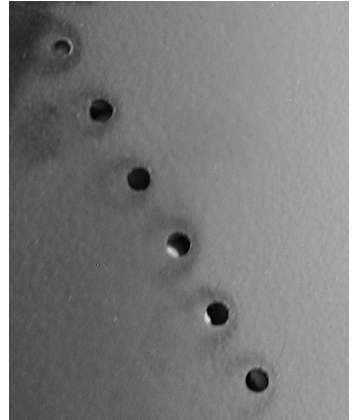

- For best results when lighting the burner, have the adjustable flame knob to the HI position, then adjust to a lower setting after the burner has ignited.
- When first lighting the pilot on the burner, it takes approximately 60 to 75 seconds to fully heat and energize the thermopile. Once the thermopile is energized, turn on the gas valve and light the burner.



KNOB SET TO HI

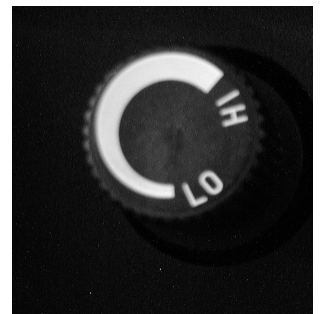

KNOB SET TO LO

# PILOT FLAME CHARACTERISTICS

Figure 19 shows a correct pilot flame pattern. The correct flame will be blue and will extend beyond the thermocouple. The flame will surround the thermocouple just below the tip. A slight yellow flame may occur where the pilot flame and main burner flame meet. Figure 20 shows an incorrect pilot flame pattern. The incorrect pilot flame is not touching the thermocouple. This will cause the thermocouple to cool. When the thermocouple cools, the heater will shut down.

**VFSU(R,E) PILOT FLAME PATTERN (VFSUE pilot will not have a thermopile)**

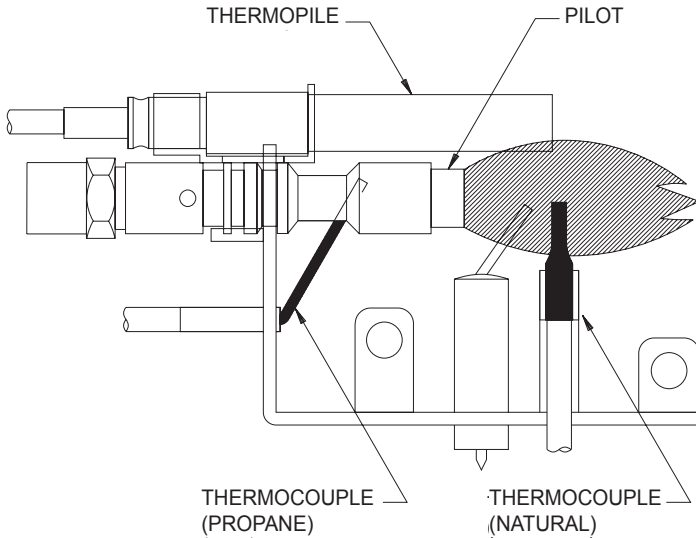

**Correct Pilot Flame Pattern  
Figure 19**

If pilot flame pattern is incorrect, as shown in Figure - 20

- See Troubleshooting, page 21.

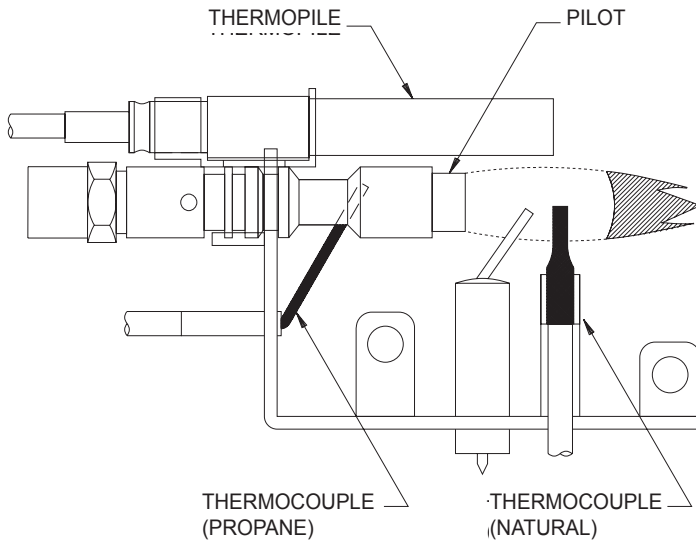

**Incorrect Pilot Flame Pattern  
Figure 20**

## CLEANING AND MAINTENANCE/PILOT

### Oxygen Depletion Sensor Pilot

When the pilot has a large yellow tip flame, clean the Oxygen Depletion Sensor as follows:

1. Clean the ODS pilot by loosening nut B from the pilot tubing. When this procedure is required, grasp nut A with an open end wrench.
2. Blow air pressure through the holes indicated by the arrows. This will blow out foreign materials such as dust, lint and spider webs. Tighten nut B also by grasping nut A.

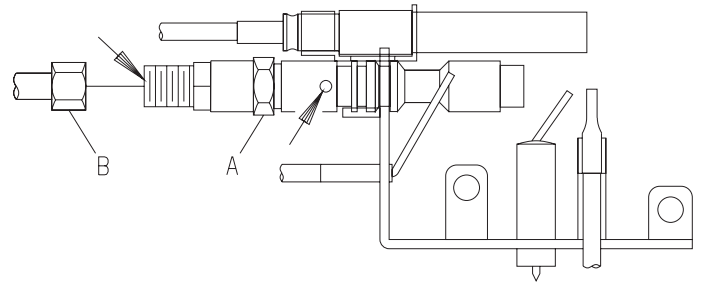

**Figure 21**

### **⚠ WARNING**

**Never use needles, wire or similar cylindrical objects to clean the pilot to avoid damaging the calibrated ruby that controls the gas flow.**

# CLEANING AND SERVICING

Annual inspection and cleaning by your dealer or qualified service technician is recommended to prevent malfunction and/or sooting.

## TURN OFF HEATER AND ALLOW TO COOL BEFORE CLEANING.

Remove logs, handling carefully by holding gently at each end. Gloves are recommended to prevent skin irritation from ceramic fibers. If skin becomes irritated, wash gently with soap and water. Refer to manual for correct log placement.

## PERIODIC CLEANING – Refer to parts diagram for location of items discussed below.

- Do not use cleaning fluid to clean logs or any part of heater.
- Logs - brush with soft bristle brush or vacuum with brush attachment.
- Remove loose particles and dust from the burner areas, controls, piezo covers and grate. Don't remove media from inside burner box.
- Inspect and clean burner air intake hole. Remove lint or particles with brush. Failure to keep air intake hole clean will result in sooting and poor combustion.

## ANNUAL CLEANING/INSPECTION – Refer to parts diagram for location of items discussed below.

- Inspect and clean burner air intake hole. Remove lint or particles with vacuum or brush. Failure to keep air intake hole clean will result in sooting and poor combustion.
- Inspect and clean all burner ports.
- Inspect ODS pilot for operation and accumulation of lint at air intake holes.
- Verify flame pattern and log placement for proper operation.
- Verify smooth and responsive ignition of main burner.
- Check level of ceramic media in burner. Burner should be full, up to the level of openings in burner top.
- On VFSUE model, check battery life and replace if needed in both remote and receiver.



# VFSUR(18,24,30) PARTS LIST

Attention: When ordering parts, it is very important that part number and description of part coincide.

INDEX NO.	PART NUMBER			DESCRIPTION
	VFSUR18(N,P)	VFSUR24(N,P)	VFSUR30(N,P)	
1	32240	32241	32242	Rear Cover Plate
2	32287	32294	32295	Grate Leg Welded Assembly
3	24553	24553	24553	Venturi Shield
4	R3624	R3624	R3624	Pilot Assembly - Natural Only
4	R3623	R3623	R3623	Pilot Assembly - Propane Only
5	32335	32337	32339	Burner Assembly (Includes Index Nos. 3 & 6) - Natural Only
5	32336	32338	32340	Burner Assembly (Includes Index Nos. 3 & 6) - Propane Only
6	R5674	R5674	R5674	Venturi Tube Assembly - Natural Only
6	R9691	R9692	R9692	Venturi Tube Assembly - Propane Only
7	R12681 (Blue)	R12681 (Blue)	R12682 (Yellow)	Air Shutter - Natural Only
7	R5676	R5695	R5695	Air Shutter - Propane Only
8	P302	-	-	Orifice #3.0 mm - Natural Only
8	P245	-	-	Orifice #50 - Propane Only
8	-	P296	-	Orifice #3.1 mm - Natural Only
8	-	P265	-	Orifice #49 - Propane Only
8	-	-	P303	Orifice #30 - Natural Only
8	-	-	P297	Orifice #1.9mm - Propane Only
9	P253	P253	P253	Fitting, Orifice Angled
10	23249	23249	23249	Valve Bracket
11	R3626	R3626	R3626	Valve - Natural Only
11	R3625	R3625	R3625	Valve - Propane Only
12	23250	23250	23250	Tubing Assembly
13	R2423	R2423	R2423	5/16 Male Connector
14	32302	32302	32302	Tubing Assembly - Natural Only
14	32303	32303	32303	Tubing Assembly - Propane Only
15	R7063	R7063	R7063	Pilot Regulator - Natural Only
16	20116	20116	20116	Tubing Assembly - Natural Only
17	32332	32333	32334	Cover Plate Assembly
18	R9028	R9028	R9028	On/Pilot/Off Extension Knob
19	R9027	R9027	R9027	Hi/Lo Extension Knob
20	R3436	R3436	R3436	Remote/Off/On Switch
21	R2313	R2313	R2313	Piezo Igniter
22	R10947	R10947	R10947	Wire Assembly
23	R5668	R5668	R5668	12" Wire Ignitor
32	R7227	R7227	R7227	3/16" Pilot Tube Fitting
N/S	15999	15999	15999	Rockwool (Ember Material)
N/S	11788	11788	11788	Decorative Rock/Lava Rock (2 Required)
N/S	R2809	R2809	R2809	Damper Clamp

USE ONLY MANUFACTURER'S REPLACEMENT PARTS. USE OF ANY OTHER PARTS COULD CAUSE INJURY OR DEATH.

# VFSUR(18,24,30) PARTS VIEW

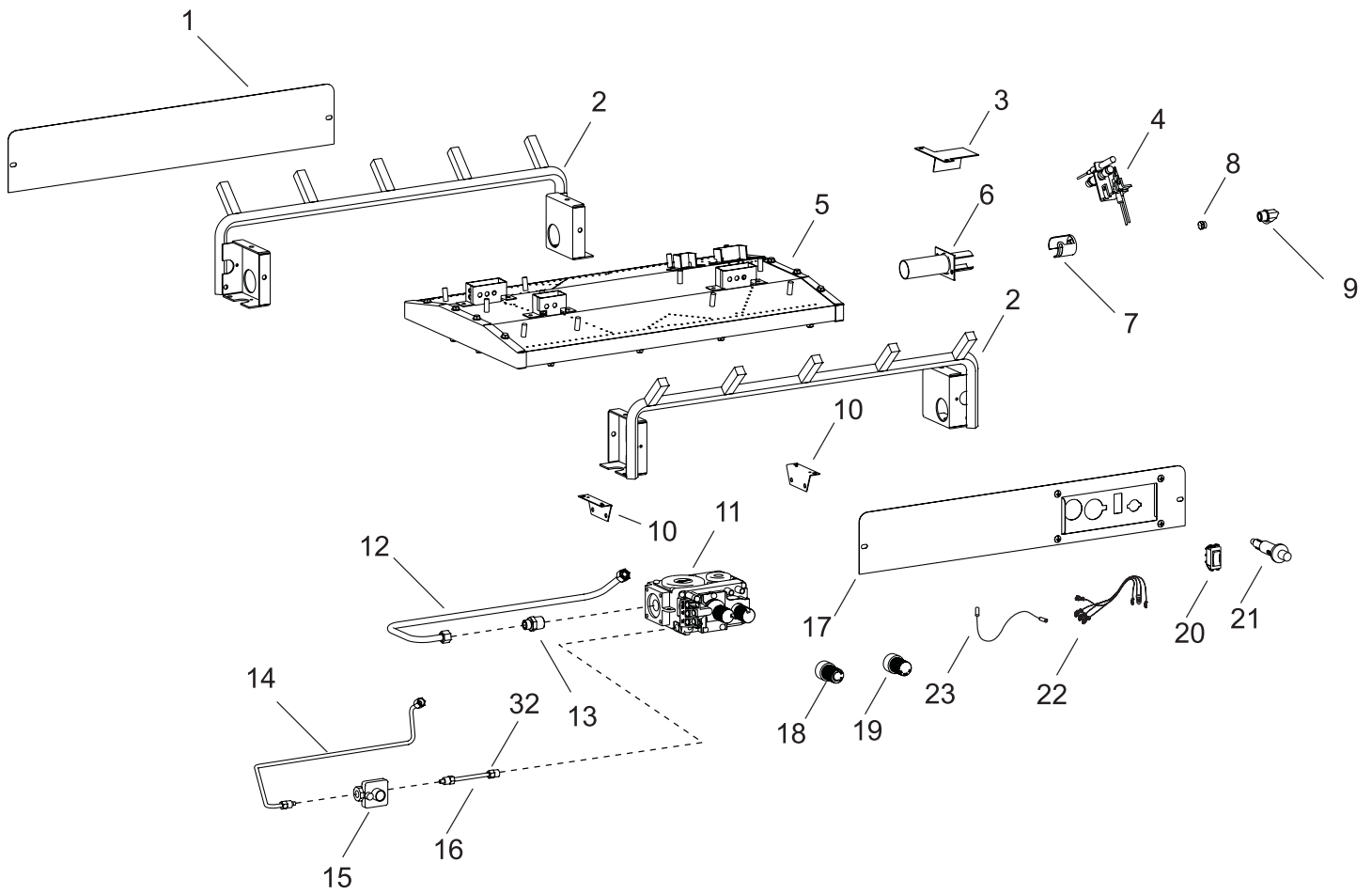

# VFSUE(18,24,30) PARTS LIST

Attention: When ordering parts, it is very important that part number and description of part coincide.

INDEX NO.	PART NUMBER			DESCRIPTION
	VFSUE18(N,P)	VFSUE24(N,P)	VFSUE30(N,P)	
1	32240	32241	32242	Rear Cover Plate
2	32287	32294	32295	Grate Leg Welded Assembly
3	32336	32338	32340	Burner Assembly - Propane
3	32335	32337	32339	Burner Assembly - Natural Gas
4	43118	43118	43118	Module Shield
5	42940	42940	42940	Cover Plate Channel
6	31716	31716	31716	Cover Plate Door
7	32237	32238	32239	Cover Plate, Front
8	42939	42939	42939	Valve Bracket
9	24553	24553	24553	Venturi Shield
10	R9691	R9692	R9692	Venturi Tube Assembly, LP
10	R5674	R5674	R5674	Venturi Tube Assembly, NG
11	R5170	R5170	R5170	Pilot Assembly - Propane
11	R5171	R5171	R5171	Pilot Assembly - Natural
12	R5676	R5695	R5695	Air Shutter - Propane
12	R12682	R12682	R12682	Air Shutter - Natural
13	P245	R265	P297	Orifice - Propane
13	P302	P296	P303	Orifice - Natural
14	P253	P253	P253	Fitting, Orifice, 90 Elbow
15	R12715	R12715	R12715	Battery Pack, Four AA Cells
16	R13121	R13121	R13121	Main Control Module
17	R13117	R13117	R13117	Pilot Adapter, Machined
18	B101393	B101393	B101393	Flex Line
19	B100100	B100100	B100100	Fitting, Brass 3/8 Flare X 3/8 MIP (Between Flex Line And Regulator)
20	R10618	R10618	R10618	Regulator, 4.0 W.C. (NG)
20	R10689	R10689	R10689	Regulator, 10.0 W.C. (LP)
21	R13118	R13118	R13118	Single Outlet Valve
22	R2423	R2423	R2423	Male Connector
23	R12717	R12717	R12717	Switch, Intermittent (Learn)
24	R12716	R12716	R12716	Switch, Two Position (ON / OFF)
25	R13258	R13258	R13258	Decal - Switch
26	42934	42934	42934	Tube Assembly - Valve To Burner
27	42935	42935	42935	Tube Assembly - Valve To Pilot
N/S	R13271	R13271	R13271	Transmitter - Thermostatic - SP-1001H/LTH
N/S	R11946	R11946	R11946	Ignitor Wire (From Module To Pilot)
N/S	R13122	R13122	R13122	V-Wire, 24" (Tan, From Valve To Module)
N/S	R13126	R13126	R13126	Wire, 4" (R13117 Adapter To Module)
N/S	R13265	R13265	R13265	Wire Harness (Control Module To Switches)
N/S	11883	11883	11883	Pilot Shield (NG Only)

USE ONLY MANUFACTURER'S REPLACEMENT PARTS. USE OF ANY OTHER PARTS COULD CAUSE INJURY OR DEATH.



# VFSUE(18,24,30) PARTS VIEW

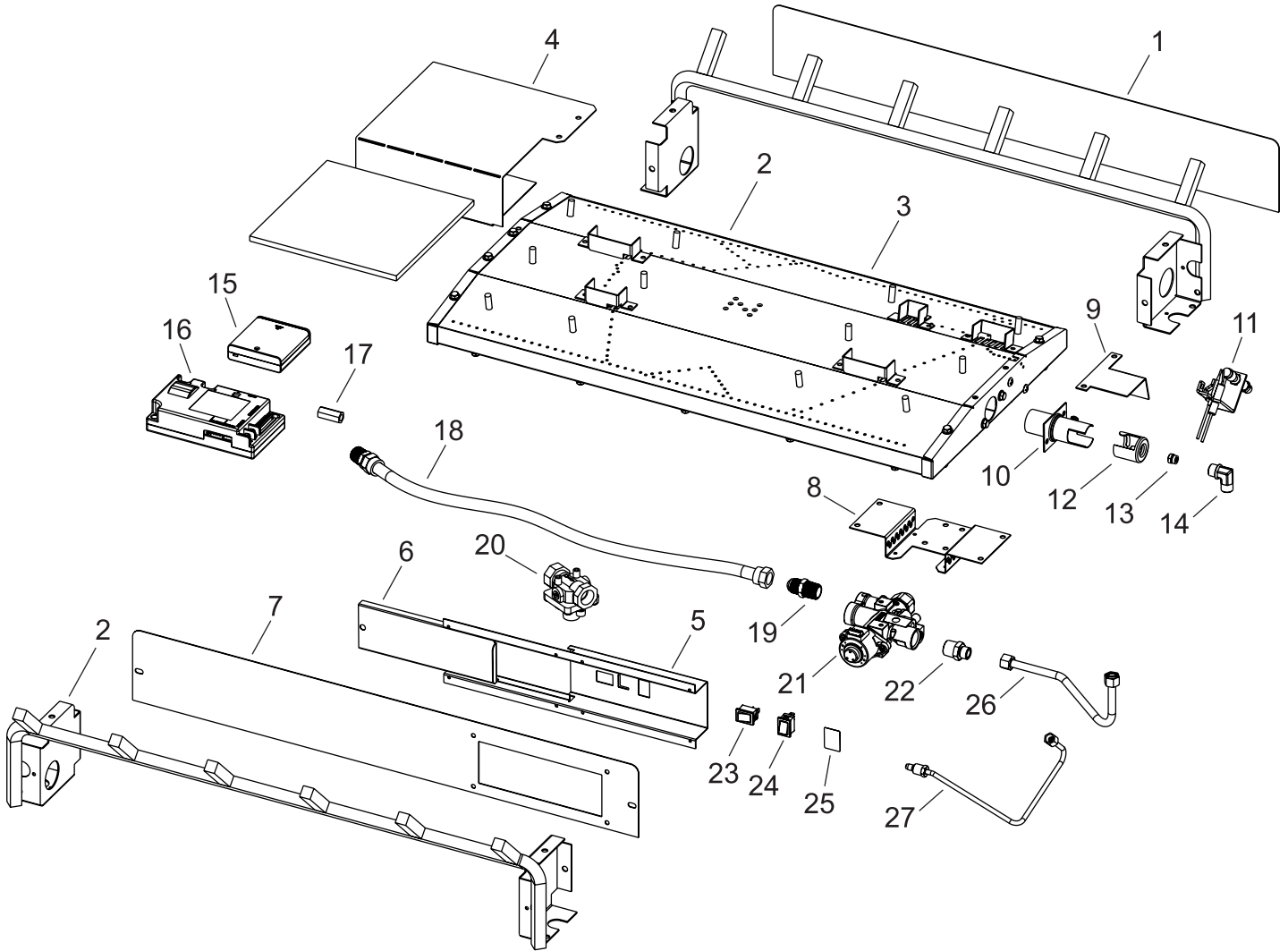

# MASTER PARTS DISTRIBUTOR LIST

To Order Parts Under Warranty, please contact your local Empire dealer. See the dealer locator at [www.empirecomfort.com](http://www.empirecomfort.com). To provide warranty service, your dealer will need your name and address, purchase date and serial number, and the nature of the problem with the unit.

To Order Parts After the Warranty Period, please contact your dealer or one of the Master Parts Distributors listed below. This list changes from time to time. For the current list, please click on the Master Parts button at [www.empirecomfort.com](http://www.empirecomfort.com). Please note: Master Parts Distributors are independent businesses that stock the most commonly ordered Original Equipment repair parts for Heaters, Grills, and Fireplaces manufactured by Empire Comfort Systems Inc.

**Dey Distributing**

1401 Willow Lake Boulevard  
Vadnais Heights, MN 55101

**Phone:** 651-490-9191

**Toll Free:** 800-397-1339

**Website:** [www.deyistributing.com](http://www.deyistributing.com)

**Parts: Heater, Hearth and Grills**

**F. W. Webb Company**

200 Locust Street  
Hartford, CT 06114

**Phone:** 860-722-2433

**Toll Free:** 800-243-9360

**Fax:** 860-293-0479

**Toll Free Fax:** 800-274-2004

**Websites:** [www.fwwebb.com](http://www.fwwebb.com) & [www.victormfg.com](http://www.victormfg.com)

**Parts: Heater, Hearth and Grills**

**East Coast Energy Products**

10 East Route 36  
West Long Branch, NJ 07764

**Phone:** 732-870-8809

**Toll Free:** 800-755-8809

**Fax:** 732-870-8811

**Website:** [www.eastcoastenergy.com](http://www.eastcoastenergy.com)

**Parts: Heater, Hearth and Grills**

## HOW TO ORDER REPAIR PARTS

**Parts Not Under Warranty**

Parts can be ordered through your Service Person, Dealer, or a Master Parts Distributor. See this page for the Master Parts Distributors list. For best results, the **service person or dealer** should order parts through the distributor. Parts can be shipped directly to the **service person/dealer**.

**Warranty Parts**

Warranty parts will need a proof of purchase and can be ordered by your Service Person or Dealer. Proof of purchase is **required** for warranty parts.

All parts listed in the Parts List have a Part Number. When ordering parts, first obtain the Model Number and Serial Number from the name plate on your equipment. Then determine the Part Number (**not** the Index Number) and the Description of each part from the following illustration and part list. Be sure to give all this information . . .

Appliance Model Number \_\_\_\_\_ Part Description \_\_\_\_\_

Appliance Serial Number \_\_\_\_\_ Part Number \_\_\_\_\_

Type of Gas (Propane or Natural) \_\_\_\_\_

Do not order bolts, screws, washers or nuts. They are standard hardware items and can be purchased at any local hardware store.

Shipments contingent upon strikes, fires and all causes beyond our control.

# WARRANTY TERMS

Empire Comfort Systems Inc. warrants this hearth product to be free from defects at the time of purchase and for the periods specified below. Hearth products must be installed by a qualified technician and must be maintained and operated safely, in accordance with the instructions in the owner's manual. This warranty applies to the original purchaser only and is not transferable. All warranty repairs must be accomplished by a qualified gas appliance technician.

**Limited Five-Year Parts & Labor Warranty – All Other Components  
(Except Remote Controls, Thermostats, Accessories and Replacement Parts)**

Should any part fail because of defective workmanship or material within five years from the date of purchase, Empire will repair or replace at Empire's option. Within five years from the date of purchase, Empire will pay reasonable labor to have that defect repaired at Empire's option.

**Limited One-Year Parts Warranty – Remote Controls, Thermostats, Accessories, and Parts**

Should any remote control, thermostat, accessory, or other part fail because of defective workmanship within one year from the date of purchase, Empire will repair or replace at Empire's option.

**Duties Of The Owner**

The appliance must be installed by a qualified installer and operated in accordance with the instructions furnished with the appliance. A bill of sale, cancelled check, or payment record should be kept to verify purchase date and establish warranty period. Ready access to the appliance for service.

**What Is Not Covered**

Damages that might result from the use, misuse, or improper installation of this appliance.  
Travel, diagnostic costs and freight charges on warranted parts to and from the factory.  
Claims that do not involve defective workmanship or materials.  
Unauthorized service or parts replacements.  
Removal and reinstallation cost.  
Inoperable due to improper or lack of maintenance.

**How To Get Service**

To make a claim under this warranty, please have your receipt available and contact your installing dealer. Provide the dealer with the model number, serial number, type of gas, and purchase verification. The installing dealer is responsible for providing service and will contact the factory to initiate any warranted parts replacements. Empire will make replacement parts available at the factory. Shipping expenses are not covered.

If, after contacting your Empire dealer, service received has not been satisfactory, contact: Consumer Relations Department, Empire Comfort Systems Inc., PO Box 529, Belleville, Illinois 62222, or send an e-mail to [info@empirecomfort.com](mailto:info@empirecomfort.com) with "Consumer Relations" in the subject line.

**Your Rights Under State Law**

This warranty gives your specific legal rights, and you may also have other rights, which vary from state to state.



SINCE 1932

[www.empirecomfort.com](http://www.empirecomfort.com)

**Empire Comfort Systems Inc.**  
**Belleville, IL**

If you have a general question  
about our products, please e-mail  
us at [info@empirecomfort.com](mailto:info@empirecomfort.com).

If you have a service or repair  
question, please contact your dealer.